



FOGO MONTANHA

INSTRUCTION MANUAL

English

PELLETS STOVE

Edge

Thank you for purchasing a FOGO MONTANHA equipment.

Please read this Manual carefully and keep it for future reference.

- * All products comply with the requirements of the Construction Products Directive (EU Reg. Directive No. 305/2011) and are approved with the CE conformity mark;
- * Pellet *stoves* have been built according to EN 14785:2008 Standards;
- * FOGO MONTANHA is not responsible for any damage to the equipment when it is installed by unqualified personnel;
- * FOGO MONTANHA is not responsible for any damage to the equipment, when the rules of installation and use, indicated in this Manual, are not respected;
- * All local regulations, including national and European standards, must be adhered to in the installation, operation and maintenance of the equipment;
- * Whenever you need assistance, you should contact the supplier or installer of your equipment. You must provide the serial number of your stove that is on the identification plate placed on the back of the equipment and on the label that is attached to the plastic cover of this manual;
- * Technical assistance must be carried out by your Installer or Solution Provider, except in special cases after evaluation by the installer or technician responsible for the assistance, who will contact FOGO MONTANHA if deemed necessary.

Technical assistance contacts:

www.fogo-montanha.com

Index

1.	Introduction	2
2.	Packing	3
2.1.	Unboxing	3
2.2.	Accessories	4
3.	Safety warnings	5
4.	For your security remind:	6
5.	Advice on action in the event of a chimney fire (including equipment)	8
6.	Dimensions	8
7.	Technical features	9
8.	Installation of smoke ducts in a <i>pellet stove</i>	10
8.1.1.	Installation requirements	10
8.1.2.	Precautions when installing fume exhaust ducts	11
8.1.3.	Examples of greenhouse fume duct installations	12
8.1.3.1.	Installation without chimney	12
8.1.3.1.1.	Conventional/non-airtight system installation with rigid smoke duct	12
8.1.3.1.2.	Airtight installation	13
8.1.3.1.3.	How does it work.....	13
8.1.3.1.4.	Dimensions required	14
8.1.3.1.5.	Installation with chimney	16
9.	Stove usage	17
10.	Fuel	19
11.	Display	20
	Remote control	20
11.1.	Menu	22
12.	Alarms / Anomalies / Errors list	31
12.1.1.	Errors list	32
13.	Installation and start-up	35
13.1.1.	Installation	35
13.1.2.	Start-up.....	36
14.	Maintenance	43
14.1.1.	Glass cleaning	43
14.1.2.	Additional cleaning (Periodic)	45
14.1.3.	Interior cleaning of combustion chamber	45
14.1.4.	Cleaning Smoke extractor	47
14.1.5.	Cleaning of the "T" inspection	47
15.	Maintenance plan	48
16.	Maintenance guide	52
17.	Installation and operation of na external "chronothermostat" control system (optional)	53
18.	Electrical schematic of the stove	54
18.1.	Electrical schematic	54
19.	Recycling	54
20.	Warranty	55
21.	Flow chart	59
21.1.	Flow chart 1 – activation	59
22.	Declaration of performance	60

1. Introduction

Thank you for choosing our FOGO MONTANHA equipment. To obtain the best performance results from your appliance while complying with ecological standards, follow the installation and operating instructions in this manual.

The warranty is no longer valid if the equipment is damaged by failure to follow these instructions.

The equipment may not be modified without the proper written permission of the manufacturer. Only factory replacement parts can be used in the appliance. National laws, local architectural standards and fire prevention regulations will have to be respected.

2. Packing

The equipment is shipped from FOGO MONTANHA facilities with the following content:

Item	Description	Qty.
1	Box	1
2	Palletization	1
3	Protective bubble	1
4	Bag	1
5	Strong bag	1
6	Pellet Stove EDGE	1

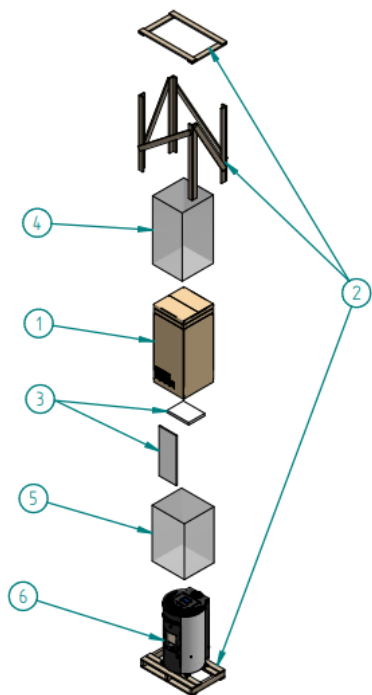

2.1. Unboxing

To proceed with the unpacking of the equipment, the retractable bag that surrounds the cardboard box must first be removed. Then remove the box by lifting it and remove the bag that surrounds the stove and the styrofoam plates. Finally, the four pieces that hold the equipment to the wooden pallet must be loosened, Figure 1.



Figure 1 - Unboxing

(9) – BAG W/ ACCESSORIES		
	<u>Comando</u>	<u>1 unidade</u>
	<u>Cabo de alimentação</u>	<u>1 unidade</u>
	<u>Manual de instruções</u>	<u>1 unidade</u>

2.2. Accessories

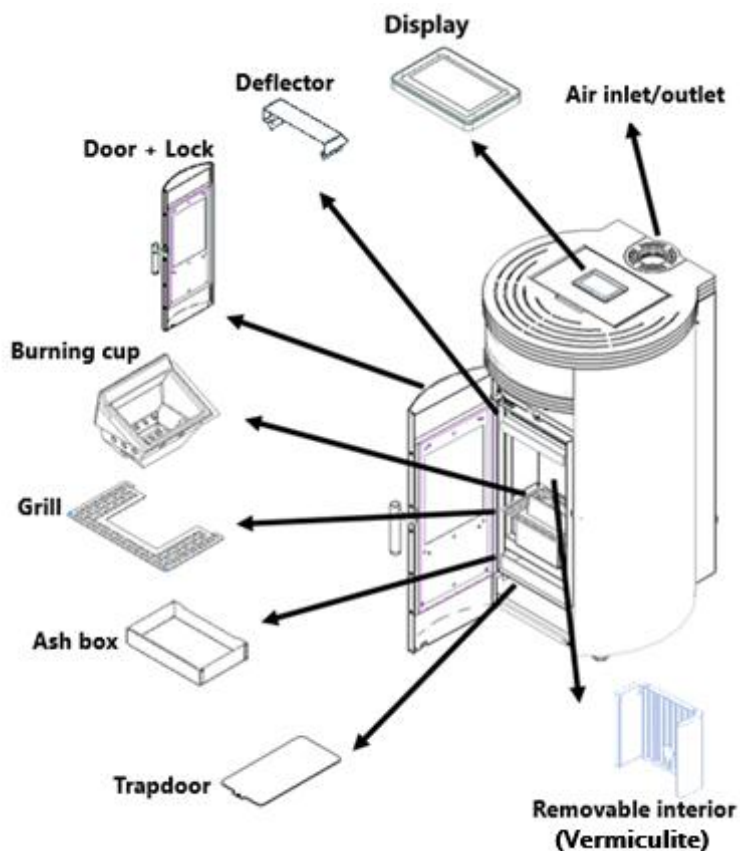

Figure 2: Main constituents of the equipment.

3. Safety warnings

- FOGO MONTANHA will not assume any responsibility if the precautions, warnings and operating rules of the equipment are not respected.
- The equipment manufactured by FOGO MONTANHA is simple to operate and special attention has been paid to its components in order to protect the user and the installer against possible accidents.
- The installation must be carried out only by authorized persons, who must give the buyer a declaration of conformity of the installation, and who will be fully responsible for the definitive installation, and consequently, for the proper functioning of the product.
- This equipment must be intended for the use for which it was expressly manufactured. All contractual or non-contractual liability of the manufacturer is excluded if it causes injury to persons, animals or things due to installation errors, maintenance or inappropriate use.
- Once you have removed the packaging, make sure that the contents are whole and complete. If the contents of the package do not correspond to point 2, contact the retailer from whom you purchased the appliance.
- All the components that make up the equipment guarantee its operability and energy efficiency and must be replaced by original parts by an authorized technical assistance center.
- Equipment maintenance should be performed at least once a year, for this, you should contact your specialized installer.
- This instruction manual is an integral part of the product. Make sure you are always close to the appliance.

4. For your security remind:

- The *pellet* stove is a biomass heating equipment and should always be handled after reading this manual in full.
- This appliance is not intended for use by persons (including children) with reduced physical, sensory or mental capabilities, or lack of experience and knowledge, unless they have been given supervision or instruction concerning use of the appliance by a person responsible for their safety. Children should be supervised to ensure that they do not play with the appliance.
- DO NOT touch the stove if you are barefoot and have wet or moist body parts.
- It is FORBIDDEN to modify the safety or regulation devices without the manufacturer's authorization.
- Do not leave packaging material at the hand of children.
- During normal operation of the appliance, the stove door cannot be opened.
- AVOID direct contact with the parts of the appliance that tend to overheat during operation, namely the door and all the elements that make it up.
- Check for any OBSTRUCTIONS in the smoke duct before switching on the appliance.
- The stove is designed to work inside homes in a protected environment. Safety systems may intervene to switch off the stove. If such a situation occurs, contact the service centre and never, under any circumstances, disarm the safety systems.
- The pellet stove is a biomass heating equipment with smoke extraction carried out by an electric extractor. Power failure during use can cause the smoke not to be exhausted and the consequent entry of the smoke into the home. For this reason a chimney with good natural extraction is advisable.
- When operating, you should NEVER disconnect the electrical plug of your *pellet* stove. The fume extractor of the *pellet* stove is electric, so it may cause the non-extraction of combustion fumes.
- To perform maintenance on your equipment, you must disconnect it from the electrical current. To do this, the equipment must be fully cooled (if it has been in operation).
- NEVER touch the inside of the stove without disconnecting it from the mains.
- NEVER install the equipment in small rooms, sanitary facilities, bedrooms, rooms with an explosive environment or others with similar conditions.

If the machine was upgraded with airtight installation

- In France, it is advisable to check DTU 24.2 for the installation of watertight stoves with concentric pipes.

If the machine was upgraded with non-airtight installation (typical)

- The *pellet* stove is an equipment that needs air to perform a correct combustion, so the possible tightness of the place where the equipment is located or the existence of other sources of air extraction in the house can prevent the correct operation of the equipment.
- External opens are essential for correct combustion.
- It is FORBIDDEN to cover, block or reduce the dimensions of the air intake grilles that allow the ventilation of the installation room.

5. Advice on action in the event of a chimney fire (including equipment)

- Try to put out the fire, without putting your life at risk.
- If within a minute you cannot put out the fire, you should call the fire brigade.
- Close the doors and windows or partition where the fire broke out.
- Turn off the electrical current and turn off the gas before leaving your residence.
- Once outside, you must wait for the fire brigade and be ready to give you the following information: location of the fire, possible materials that are burning and what they can do to stop the progression of the fire.

6. Dimensions

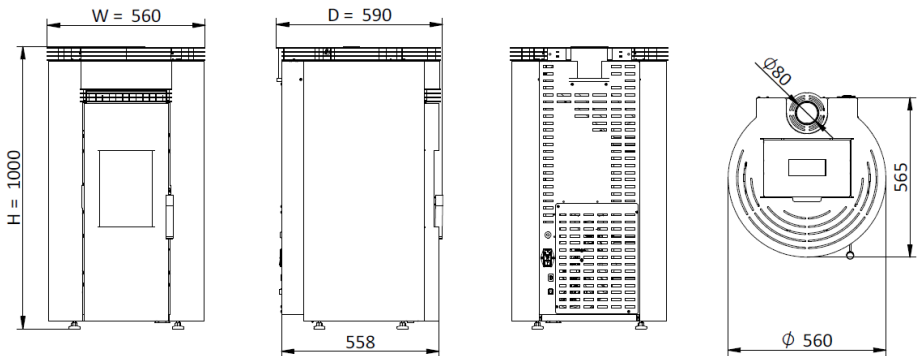

Figure 2 - Dimensions

7. Technical features

Characteristic	Values
Gross weight	91,5 kg
Height	1000 mm
Width	560 mm
Depth	590 mm
Diameter of the smoke discharge pipe	80 mm
Coaxial tube diameter air inlet/smoke outlet	130/80 mm
Tank capacity	15 kg
Maximum heating volume	159 m ³
Maximum global heat output	7 kW
Minimum overall thermal input	4 kW
Maximum fuel consumption	1,57 kg
Minimum fuel consumption	0,68 kg
Power	102 W
Power at start-up (<10min)	378 W
Voltage	230 V
Nominal Frequency	50 Hz
Thermal Yield at Rated Thermal Power	92%
Thermal performance at reduced thermal power	96%
Gas flow rate (Max)	5 g/s
Gas flow rate (Min)	3 g/s
Gas temperature (Max)	137 °C
Gas temperature (Min)	100 °C
CO emissions at rated thermal input	0,01%
CO emissions at reduced thermal power	0,02%
Depression in the chimney	12 Pa
Internal tangential fan power	59 W
Power fan for ductable air (optional)	N/A
Internal tangential fan flow	305 m ³ /h
Auxiliary fan flow rate	-

Table 1 - List of technical characteristics

Note: Tests carried out using wood *pellets* with a calorific value of 4.9 kWh/kg. The above data were obtained from the product approval tests in independent and accredited laboratories to carry out tests on *pellet equipment*.

8. Installation of smoke ducts in a *pellet stove*

Before you start the installation, perform the following actions:

- Take the user manual, read it carefully and hand it over to the customer.
- Check that the product is delivered complete and in good condition. Any defects must be noted before installing the appliance.
- The stove has four height-adjustable feet at the base allowing for simple adjustment on non-level floors.

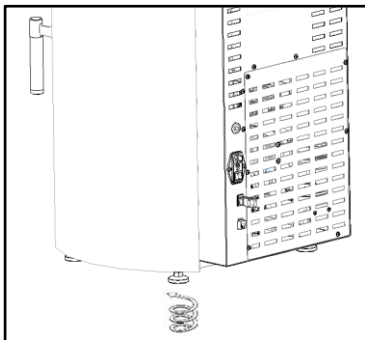

Figure 3 – Equipment adjustment

8.1.1. Installation requirements

The minimum distances from the *pellet stove* to especially flammable surfaces are shown in Figure 4.

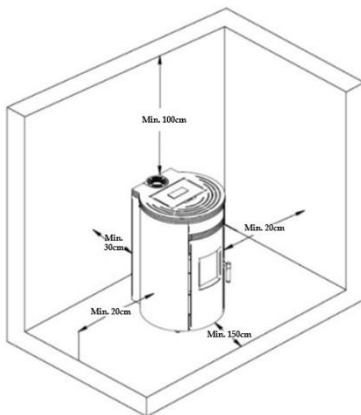

Figure 4 - Minimum distances from all surfaces

- The base where the stove rests cannot be made of combustible material (e.g. carpet), so there must always be adequate protection, and it must also be strong enough to support the equipment.

 **WARNING!**

If the stove is installed in a place where objects are believed to be particularly delicate, such as curtains, sofas and other furniture, the safety distances should be increased.

Keep combustible and flammable materials at a safe distance.

8.1.2. Precautions when installing fume exhaust ducts

- The construction of the exhaust gas pipe must be suitable for this purpose in accordance with the requirements of the site and in compliance with the regulations.
- When installing the chimney pipe and you need to drill a hole in a wall or ceiling of the house, you have to pay attention to the material in which they are built. If the construction material is heat-sensitive (e.g. wood), drill a hole and place a special wall connection with a minimum of 13 cm in inner diameter, and then insulate the pipe from the machine's smoke outlet with a suitable insulation material. (e.g. 1.35 thickness with a thermal conductivity of 0.07 W/m⁰K).
- If the installation of the smoke duct is close to a wall (less than 20 cm) where the above condition is met, the pipe must be insulated.
- We recommend as an alternative to insulation the use of insulated piping that should be used outdoors to avoid condensation.
- Under nominal operating conditions, the flue gas draft shall cause a depression of 12 Pa, measured 1 metre above the chimney neck.
- The stove cannot share the chimney with other equipment.
- Pipes outside the place of use must be double insulated in stainless steel, with an internal diameter of 80 mm.
- The fume exhaust pipe can generate condensation, in which case it is advisable to establish adequate condensate collection systems.

8.1.3. Examples of greenhouse fume duct installations

The installation of the *pellet stove* can be carried out in two different ways, in a first solution the exit of the smoke duct can be carried out through the internal pipe (conventional) admitting the ambient / local air. In a second solution, the exit of the smoke duct can be carried out coaxially, allowing the equipment to exceptionally consume air from the outside.

8.1.3.1. Installation without chimney

8.1.3.1.1. Conventional/non-airtight system installation with rigid smoke duct

WARNING!

You must ensure that the fittings between the different tubular elements in both options are **CORRECTLY** placed and sealed to prevent possible leakage of harmful gases into the dwelling.

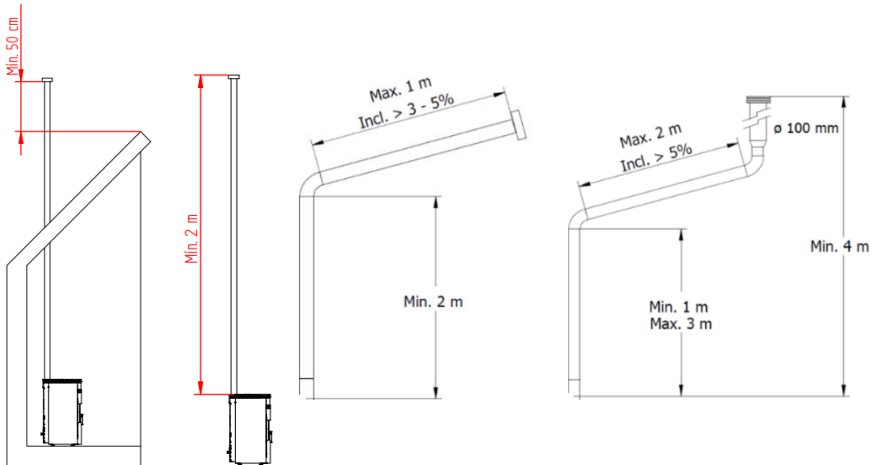
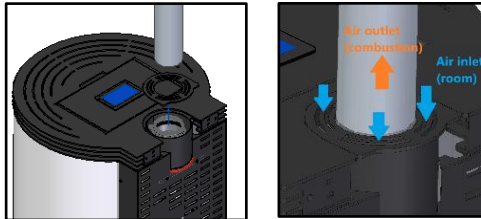

 The smoke outlet must be equipped with a suitable waterproof terminal that complies with local regulations.

 The length of the exhaust duct shall not exceed 6 metres with the 80 mm diameter pipe.

8.1.3.1.2. Airtight installation

WARNING!

Both the smoke outlet and the air intake in this situation must not be disturbed (e.g. curves) or reduced. The air inlet and smoke outlet of the equipment is 80/130mm respectively.

8.1.3.1.3. How does it work

The coaxial system allows the entry of combustion air and the evacuation of fumes through the same duct.

The combustion air heats up when it encounters fumes. Hot air injection (controlled) enables combustion optimization.

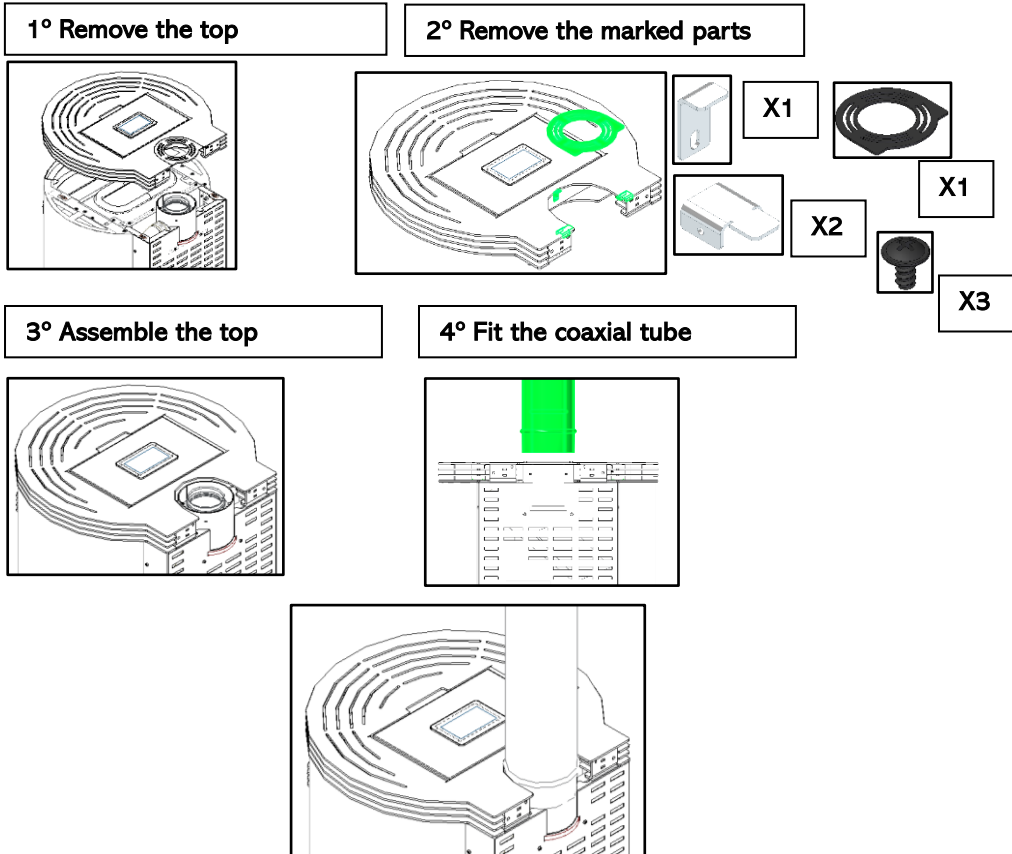

8.1.3.1.4. Dimensions required

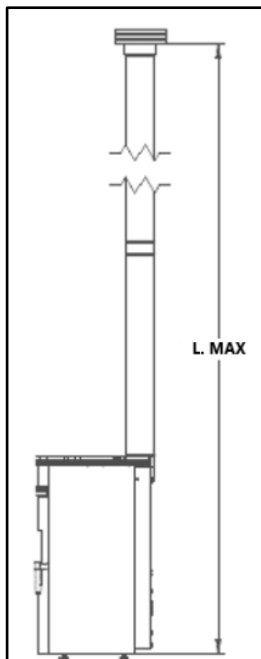

Ø COND
Ø 80/130 mm

L. MAX
4,5 m

Figure 5 - Example of a Type A Installation

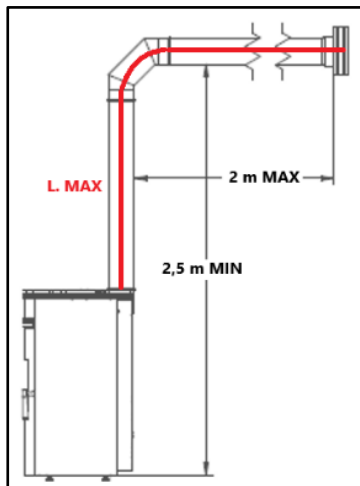

Ø COND
Ø 80/130 mm

L. MAX
4,5 m

Figure 6 - Example of a Type B Installation

Minimum ground distance

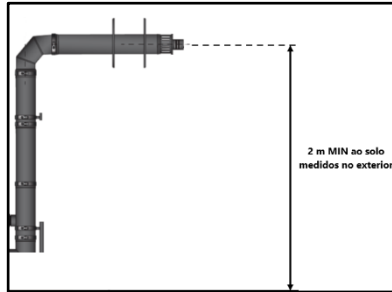



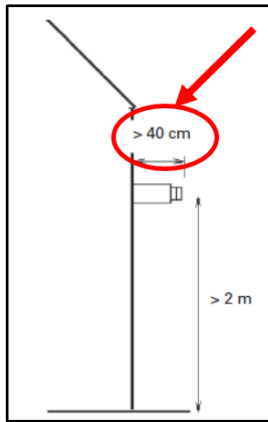

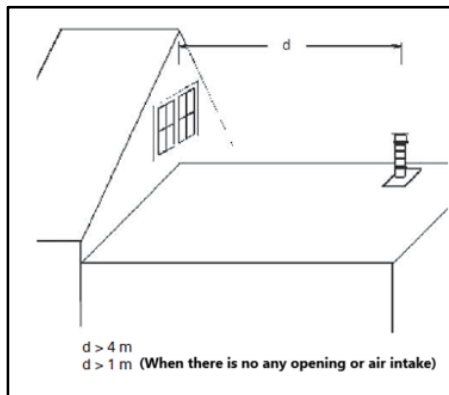

Minimum horizontal exit distance



Distance to a floor in the same room, compartment or air intake



8.1.3.1.5. Installation with chimney

-  **NOT ALLOWED** Use of flexible stainless-steel pipe or smooth steel pipe.
-  **YOU MUST NOT** place more than 3 bends (max. 45°) in a smoke duct installation.
-  Failure to comply with these requirements jeopardizes the correct functioning of the stove. Fully respect the indications of the schemes.
-  Stoves operate with the combustion chamber in depression, so it is absolutely necessary to have a fume evacuation duct that extracts the flue gases properly. If the house has an air extraction system (e.g. kitchen hood) it will be necessary to have an upper ventilation section, with a size adapted to the different equipment that extracts air from the house. Installing the stove in areas where there are kitchen hoods or fume extractors may impair the proper functioning of the stove (if it is being fed by air from the room).
-  All smoke ducts must be accessible.
-  The chimney or the smoke ducts that are connected to the stoves must be cleaned at least once a year (check if there are regulations on this point in the country itself). Failure to check or clean regularly increases the likelihood of chimney fire.

Smoke pipe material: The pipes to be installed must be rigid, made of stainless steel with a minimum thickness of 0.5 mm, with joints for the connection between the different sections and fittings.

Isolation: Smoke ducts should preferably be double-walled insulated to ensure that the fumes do not cool down on the way outside, which would lead to inadequate draught and condensation which could damage the appliance.

Chimney depression: The figures illustrate standard schemes, with the appropriate lengths and diameters. Any other type of installation must ensure that a depression of 12 Pa (0.12 mbar) measured at hot and maximum power is generated.

Ventilation: For the stove to function properly, the appliance must have an air inlet with a minimum cross-section of **100 cm² (only when it is used in ventilated mode)**, preferably near the back of the stove. When the stove is operated using coaxial piping, this air intake is no longer necessary in the room where it is installed.

9. Stove usage

 It's required to carry out a start-up service as mentioned in section 3.6, page 55 (Warranty). To adjust the operating parameters of the stove (pellet equipment) you must adjust the dose as described in point 14 of this manual. It is necessary to adjust the pellet dose according to the gas temperature and pellet consumption of the appliance at the rated power described in Table 1, in order to ensure that the equipment delivers the correct power.

Recommendations

Before starting the appliance, it is necessary to check the following points:

Plug the 230VAC power cord into an earthed power outlet. The electrical plug is located on the right side of the machine under the side cover in the case of the machine Figure 7.

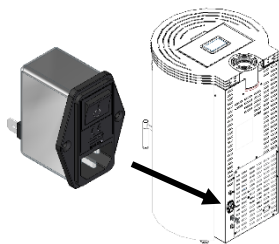

Figure 7 - Electrical current plug and its placement

- Check that the *pellet* tank is filled.

- It should be checked that there is sufficient air circulation in the room where the installation is made, otherwise the equipment will not work properly. For this reason, you should pay attention to whether there are other heating equipment that consumes air for its operation (e.g., gas equipment, braziers, exhaust fans, etc.), it is not advisable to operate these equipment at the same time (if ventilated/conventional).

- The equipment have a probe to measure the ambient temperature. This probe is fixed to the grille on the back, Figure 8. For the most accurate reading of the ambient temperature, avoid contact of the probe end with the machine frame. If you wish, you can also fix it on the wall next to the machine.



Figure 8 - Ambient temperature probe

- On the first use of the stove, the paint is cured, which can lead to the production of additional fumes. If this is the case, you should air out the compartment, opening the windows and doors to the outside.
- Avoid touching the equipment during the first firing so as not to leave permanent marks on the paint as it goes through a more plastic phase during its curing process. The ink cures at approximately 300°C for 30 minutes.

10. Fuel

- Pellets are the only fuel to be used for the stove to function. No other fuel can be used.
- Use only wood *pellets* certified to the EN 14961-2 grade A1 standard with Ø of 6 mm and a length that can range between 10 and 30 mm.
- The maximum permissible moisture for *pellets* is 8% by weight. To ensure good combustion, pellets must maintain these characteristics, so it is recommended to store them in a dry place.
- The use of different *pellets* reduces the efficiency of the stove and leads to faulty combustion processes.
- Choose only certified pellets. On the other hand, before buying large quantities, we advise you to try a sample.
- The physicochemical properties of *pellets* (including size, friction, density, and chemical composition) can vary within certain tolerances and depending on the manufacturer. This can cause changes in the feeding process and consequently different dosages (with more or less *pellets*).
- The stove allows the pellet dose to be adjusted in the start-up phase and in the power levels by $\pm 25\%$.



WARNING : The appliance can NOT be used as an incinerator, i.e. it can only use pellets as a fuel source.

11. Display

- The stove includes a *display* that manages several functions and allows programming and interaction with the appliance.
- There is also a remote control that allows remote access to some of the equipment's functions.



Device	Functionality
	Visualization and interaction with equipment parameters and functions.
	The remote control allows you to turn the stove on and off and increase or decrease the power level of the equipment.

Table 2 – Electronic devices

Remote control

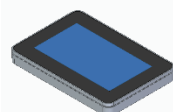

Figure 9 - Radio remote control

The remote control allows the stove to be switched on and off and the equipment can be changed (for this the stove cannot be on automatic). You may need to pair your controller, and you must:

- 0- The machine has to start off and then putting 1 load.
- 1- Press and hold the 2 buttons (Combinations: 1-2, 1-3, 1-4, 2-3, 2-4, 3-4).
- 2- The led starts flashing.
- 3- After 10s, the led stays on.
- 4- After the led is fixed, stop pressing the buttons in less than 5s.
- 5- If you do not fail to press the buttons, the LED will turn off and the serial number will not be changed (accidental pressure protection) and the remote control will no longer be paired with the stove.

List of frequencies emitted according to button combinations:

Button Combination	Frequência (bit)
1-2 (default)	00000100
1-3	00000101
1-4	00000110
2-3	00001001
2-4	00001010
3-4	00001100

Lista de Códigos:

Button	Code (bit)
Button 1 (ON)	Code: 11
Button 2 (+)	Code: 01
Button 3 (-)	Code: 00
Button 4 (OFF)	Code: 10

This remote runs on two CR2016 3V batteries, like the one in the picture below.

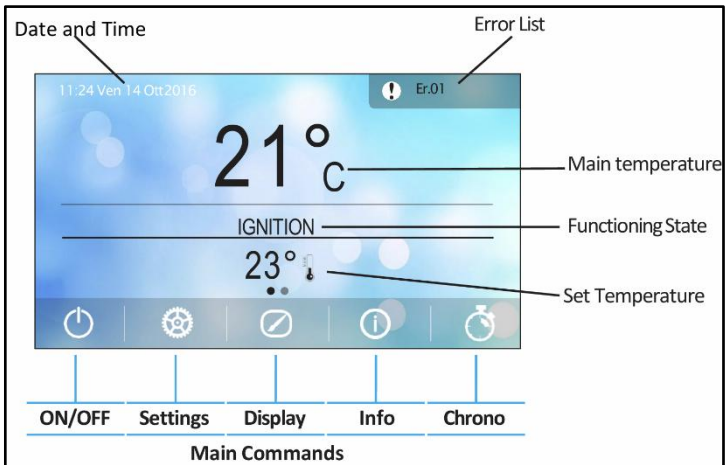

Figure 10 - Command Stacks

Note: you need to activate the command on the display.

11.1. Menu

When connecting the equipment to electricity, the device's display indicates the status of the equipment and may indicate system errors, current ambient temperature and selected ambient temperature set-point.



HORIZONTAL SWIPE

Swiping to the left brings up a menu showing all active sensors/logs. Whenever one of the symbols is lit, it is a sign that it is working.

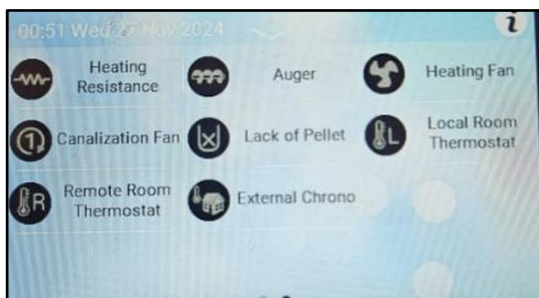



VERTICAL
SWIPE

Swiping down the screen shows the main functions known as:

- Power – Power level

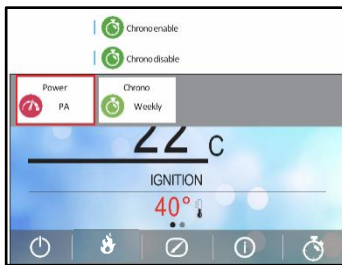

- Chrono – chrono programming

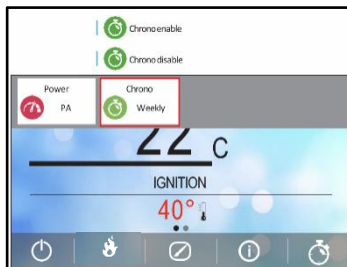

Tap the screen to exit.

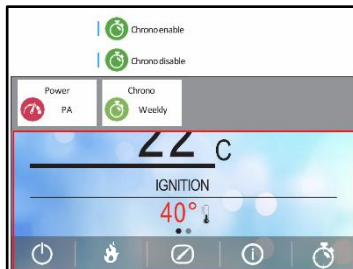

11.1.1. Menus

11.1.1.1. ON/OFF

Clicking on this first icon, we have access to the command to turn the machine on/off.



To start-up the machine (**section 13.2.1**)

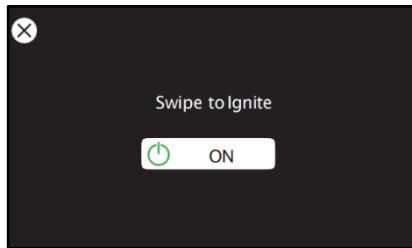





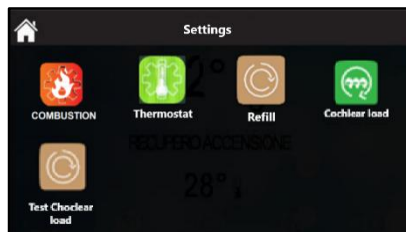

11.1.1.2. Settings

Clicking on this icon we have access to some parameters that we can monitor/configure.



Here are the parameters we can configure



	<p>Combustion</p> <p>In this menu, you can configure the combustion power of the system. It can be set in automatic or manual mode: in the first case, the system will choose the combustion power, in the second case, it is the user who selects the desired power. The left side from display will show the combustion mode (A=automatic combustion, M>manual combustion) and the operating power of the system.</p>
	<p>Heating</p> <p>In this menu, you can configure the heating power of the system. It can be set in automatic or manual mode: in the first case, the system will choose the combustion power, in the second case, it is the user who selects the desired power. On the right side, the display indicates the heating mode (A=automatic, M>manual) and the relative power.</p>
	<p>This menu allows you to modify the value of the main thermostat by adjusting it to a user-defined value.</p>
	<p>In this menu, the system is informed of the number of pellets in the tank and consequently calculate the fuel consumed. Four charge levels are available: 100% (full tank), 75%, 50%, 25%, 0 (function off). At the time of loading, the user must set the level of the refilled pellet tank.</p>
	<p>The procedure activates manual pellet loading and it will automatically stop after 300 seconds. The worm motor starts continuously and the combustion fan runs at power 3. The system must be turned OFF for the function to run.</p>
	<p>This menu allows the technician/user to test, depending on the pellet used, what the pellet flow rate is. The procedure activates the manual loading of the pellets at the intermediate speed. The worm motor starts in continuous mode at a speed of 1500 rpm and the combustion fan runs at power 3. Start time tracking. At the end of 300 s stop. Weigh the number of pellets fed and conserve the value (in grams) Repeat the action 3x. Average the value obtained and multiply by 2. At the end, put the average value at P112 (technical access required). The Refill system is now adjusted to the pellet used. The system must be turned OFF for the function to run.</p>

11.1.1.3. Customization



In this menu, all the functional variables of the control panel are displayed.

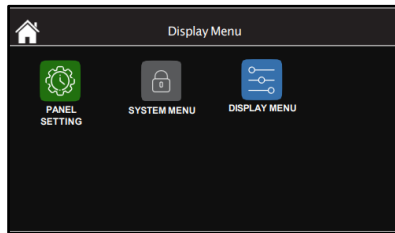

The following items are displayed for configuration



	<p>Date and time</p> <p>This menu allows you to set the current day, month, year, and time</p>
	<p>Language</p> <p>This menu allows you to modify or modify your language.</p>
	<p>Remote control</p> <p>OFF</p> <p>ON</p>
	<p>Cleaning Reset</p> <p>Reset of the "system maintenance 2" function, i.e. cleaning.</p>
	<p>Auger Configuration</p> <p>This menu allows you to modify the default values set up to 25% (increment, or decrease), speed, or auger feed time. The value can be set within the range -7 to +7. The default value is 0.</p>
	<p>Fan Configuration</p> <p>This menu allows you to modify the default values set This menu allows you to modify the default values set up to 21% (increment or decrease) of the combustion fan speed. . The value can be set within the range -7 to +7. The default value is 0.</p>
<p>Heating Fan Configuration</p> <p>This menu allows you to modify the default values set up to 14% of the fan speed. Values can be set within the -7÷+7 range. The default value is 0.</p>	

	<p>Standby</p> <p>This menu allows you to choose whether the system should switch to Modulation (Off) or Standby (On) once the temperature value programmed by the room thermostat has been reached.</p>
 <p>SYSTEM MENU</p>	<p>The "System Menu" is intended only for Technical Personnel and is protected with a 4-digit PASSWORD.</p>
	<p>Luminosity</p> <p>This menu allows you to adjust the brightness of the screen.</p>
	<p>Contrast</p> <p>This menu allows you to adjust the contrast of the screen.</p>
	<p>Minimum brightness</p> <p>This menu allows you to adjust the brightness of the screen on which the screen is placed after 30 seconds of inactivity.</p>
	<p>Standby Display</p> <p>Activates, or, deactivates the standby of the display. If activated, the display switches to standby after 1 min.</p>
	<p>Screen saver</p> <p>Used in Bus Mode.</p>
	<p>Control Panel Address</p> <p>Utilizado no Modo Bus.</p>
 <p>DISPLAY MENU</p>	<p>Reboot control Panel</p> <p>This menu allows you to reboot the Panel.</p>
	<p>Sound</p> <p>This menu allows you to turn on/off the sound of the control panel.</p>
	<p>Turn off list of errors</p> <p>Allows you to turn off the list of errors.</p>
	<p>Nodes list</p> <p>This menu allows you to check the Display and Board Firmware codes. Info can be important for FVO.</p>
	<p>Wallpaper</p> <p>This menu allows you to choose the control panel wallpaper.</p>
	<p>Control Panel Info</p> <p>This menu allows you to check the technical information of the display.</p>
	<p>DarkStyle</p> <p>This menu allows you to enable dark vision of the dashboard.</p>

11.1.1.4. Information

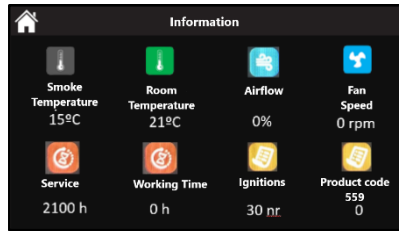

The following table is explicit to the meaning of each of the variables.

Smoke Temperature [°C]	Read in degrees Celsius (°C) informs the exhaust temperature monitored by the thermocouple.
Room Temperature [°C]	Read in degrees Celsius (°C) informs the ambient temperature monitored by the NTC probe placed outside the stove.
Airflow [lpm]	Read in liters per minute quantifies the amount of heated air moved per unit of time to the surrounding environment.
Fan Speed [rpm]	Read in revolutions per minute tells you the rotational speed of the pump.
Service [h]	Read in hours informs the number of hours missing to report anomalies due to lack of maintenance. They must be reset by the technical service at the time of maintenance. The maintenance period must respect the kilos of <i>pellets</i> burned.
Working time [h]	Read in Hours tells you the number of hours in On, Modeling and Safety.
Ignitions [nr]	Read in number of occurrences informs how many ignitions have been made since they were reset.
Product Code 559	Product Code.

Table 3 - Meaning of the variables

11.1.1.5. Chrono setting

Stove has a time programmer that serves to turn the stove on and off. It can be daily (it is possible to select the desired day of the week and set up to 3 different times for the respective day), weekly (it is possible to select up to 3 times during a day, the same program will be applied every day of the week) and Week/Weekend (it is possible to select 3 times during the day for weekdays and weekends). After analyzing the available options, select the desired modality.

Click on the icon displayed on the right of the screen.

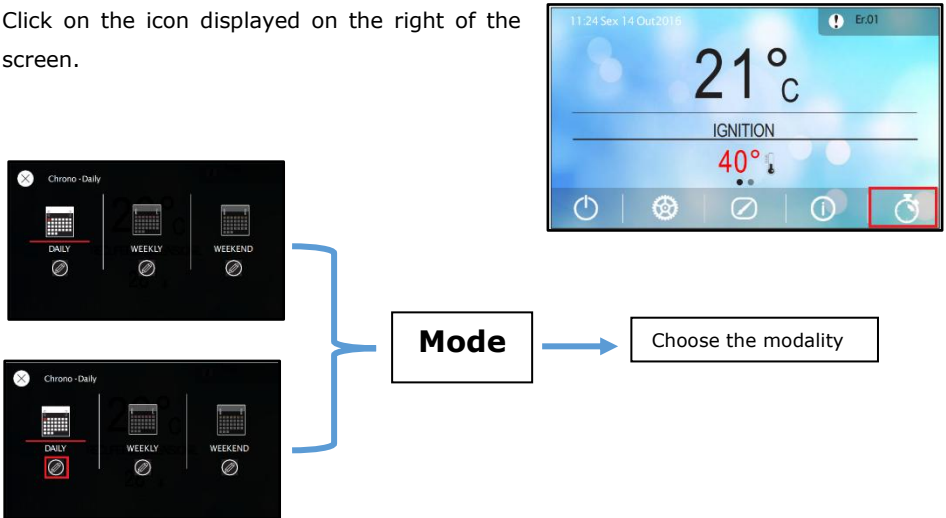

AFTER DEFINING THE DESIRED CRONO MODALITY, DEVELOP THE RESPECTIVE PROGRAMS.

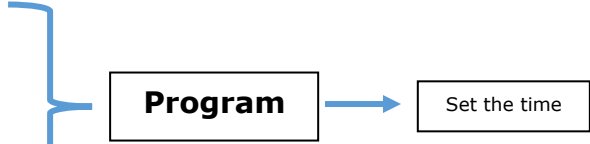
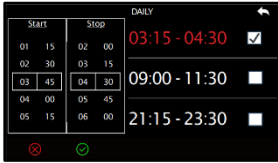
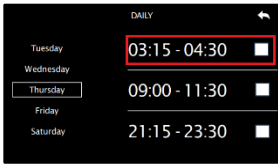

Example (Today: 2025/02/25 14:15)
Mode: Daily

Objective: *"Schedule the equipment to be on during the night."*

Program:

- Set ON for 20:30 today
- Set OFF for 23:59 today
- Set ON for 00:00 for the next day
- Set OFF for 06:30 for the next day

When programs are developed around midnight with the intention of starting the operation the day before and finishing the operation the next day, it will be pertinent:

- Finish the last program the day before at 23:59;
- Start the first program the next day at 00:00;

12. Alarms / Anomalies / Errors list

Anomalies

Sond	Display of the status of the temperature probes. The message appears during the Check Up phase and indicates that the temperature detected by one or more probes is equal to the minimum or maximum value (depending on the probe in question). Check that the probes are not open (detection of the minimum value of the temperature scale) or short-circuited (detection of the maximum value of the temperature scale).
Ignition block	Message that appears when the system has been turned off not manually in the Ignition phase (after Pre-Charge): the system shuts down only when it reaches maximum capacity.
Link Error	Lack of communication between the keyboard and the electronics board.
Cleaning On	The system is performing periodic cleanup
Service	Message indicating that the boiler has more than 2100 working hours. Contact your service representative for maintenance.

ANOMALIES DO NOT CAUSE EQUIPMENT SHUT DOWN.

To turn off the appliance, in case of emergency, you must do the normal shut down of the equipment. To do this, you must press the off button for 3 seconds and allow the deactivation until the word off appears on the display.

Only when the machine stops:

All alarms cause the machine to be deactivated with error information and activation of the alarm led. It will be necessary to "reset" the alarm and restart. To reset the machine, press the "On/Off" button for 3 to 4 seconds until you hear the beep, accompanied by a message "Reset alarms in progress".

In the Off state, if for any reason the smoke temperature rises above 85°C, the equipment enters the deactivation mode.

Important note: The burner should always be cleaned before restarting the machine!

12.1.1. Errors list

If no warning appears in the upper right corner, the machine is perfectly functional and error-free!!!



If a warning appears in the upper right corner "ErXY", the machine has detected an anomaly.



Clicking on the error message will show a list with all the errors detected by the machine.

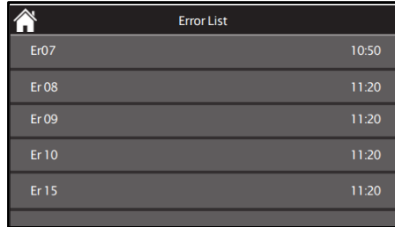

BLOCKING ERROR - LEAD TO EQUIPMENT SHUT DOWN

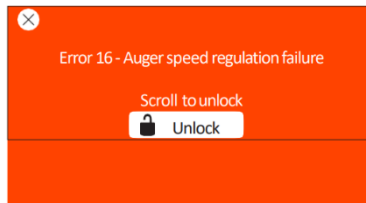

NO-BLOCKING ERROR - THEY DO NOT CAUSE EQUIPMENT SHUT DOWN

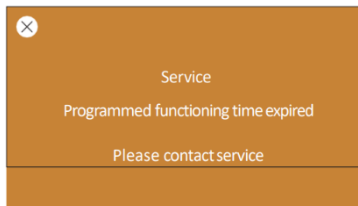

Alarm	Code		Cause and Resolution
Excess temperature in the pellet vat	Er01	110 °C, even with the device off	<ul style="list-style-type: none"> - Room fan not working – call for assistance - Faulty thermostat – call for assistance - Machine with poor ventilation
Smoke pressure switch alarm	Er02	Door open, lack of depression or pump failure for 180 s Only visible if extractor On	<ul style="list-style-type: none"> - Close the door and remove the faulty pressure switch error - Exhaust pipe clog or faulty extractor
Flame extinguished or lack of <i>pellets</i>	Er03	Smoking temperature below: 55°C (Th03)	<ul style="list-style-type: none"> - Empty <i>pellet</i> tank - Clogged <i>pellet</i> channel
Excess Temperature of Fumes	Er05	More than 300 °C	<ul style="list-style-type: none"> - Room fan does not work or is at a low power level – increase the level to maximum (if the problem persists, call for assistance) - Insufficient print run - Over-feeding of <i>pellets</i> - Faulty smoke probe
Thermostat Pellet Tank Open	Er06	-	-
Smoke extractor error	Er07	No rpm signal. Allows temporary unlocking and work P25=0	<ul style="list-style-type: none"> - Check connection - Verify that the fan is not blocked - After correction of the malfunction, it is necessary to reselect operating mode P25=2
Smoke extractor encoder error	Er08	Encoder has signal, but failed to regulate Allows temporary unlocking and tension work P25=0	<ul style="list-style-type: none"> - Exhaust pipe clog or faulty extractor - After correction of the malfunction, it is necessary to reselect operating mode P25=2
Misfire	Er12	Maximum time: 900 s and Smoke temperature less than 50°C	<ul style="list-style-type: none"> - Empty auger channel – restarting - Burnt Resistance Ignition – Replace Resistance - Burning box not fixed - Smoke temperature has not exceeded the value set at activation

Power voltage off	Er15	Feed cut-off for more than 50 min	<ul style="list-style-type: none"> - Check supply voltage with the electric power supplier - Check the simultaneity of use of electrical appliances - In the event of a short power failure (<10s) the stove continues to work normally - If the system was in ON and the power failure occurs for more than 10 seconds and less than 50 minutes, the stove develops a light after blackout
Communication failure with LCD control	Er16		- Verify Connection Between Plate and Display
Minimum air flow in Check Up	Er41		
Maximum Air Flow exceeded	Er42		
Open door error	Er44	Door open for 60 sec.	- Close the door – remove the error
Auger Encoder: Encoder signal missing	Er47		
Auger Encoder: speed regulation failed	Er48		
Service	Service	Maximum Hours 2100 hr (T66) planned for maintenance achieved	- Contact your installer or repairer for one-off preventive maintenance on the equipment

THE MAINTENANCE ANOMALY ("SERVICE" MESSAGE ON THE DISPLAY) MEANS THAT THE STOVE HAS MORE THAN 2100 HOURS OF SERVICE. THE CUSTOMER MUST MAINTAIN THE EQUIPMENT AND ONLY THEN RESET THE HOUR COUNTER TO ELIMINATE THE ANOMALY MESSAGE. THIS DOES NOT INFLUENCE THE NORMAL OPERATION OF THE EQUIPMENT, IT IS ONLY A WARNING.



Warning!



ALL EQUIPMENT MUST BE SERVICED WHEN:

- 800 KG OF PELLETS WERE BURNED

OR

- 2100 HOURS OF SERVICE

DETERMINES THE MAINTENANCE DATE WHICHEVER COMES FIRST

13. Installation and start-up

13.1.1. Installation

The installation of the stove must be carried out by an accredited professional (by local standards/directives and/or recognized by the manufacturer) in order to ensure its proper functioning and safety. In the installation phase, it is essential that the professional proceeds to the following steps:

- **Analysis of the compliance of the equipment and peripherals installation**, complying with the assembly and installation instructions available in the installation manual;
- **Verification of the conformity of the fuel used**, namely, humidity and quality, as well as its adjustment (certification by the **EN 14961-2 grade A1 standard** with a diameter of 6 mm and a length that can vary between 10 and 30 mm. The maximum permissible moisture content for fuel pellets is equal to 8% of its weight (% w/w);
- **Development technical report** giving an account of the main elements analyzed in the installation;
- **Explanation of guarantees and operating principles**;
- **Completion with information/training** (exemplify), using if possible, the label alluding to the theme on procedures of Preventive Review by the user, and technician certified by the brand;



13.1.2. Start-up

At first start-up its required:

- Check if the pellet tank is stocked;
 - Not fuel?

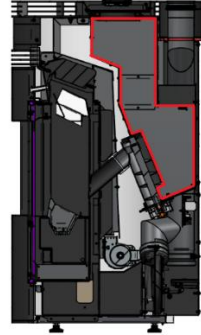

- Preload to ensure that the supply channel is full.
Note: if the channel is started without being properly filled with pellets, an error may occur that leads to the miscarriage of the ignition.

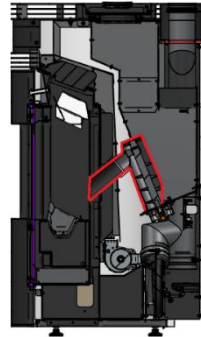

From start-up to the stabilization and stop phase, it should follow the following iterations:

- a) Preload (at first use)
- b) Ignition
- c) Flame stabilization
- d) Power level
- e) Run mode
- f) Feeding
- g) Stop

The following is the explanation of each of the points mentioned above

13.1.3. Preload

Click on the following icon:



Select "**cochlear load**"

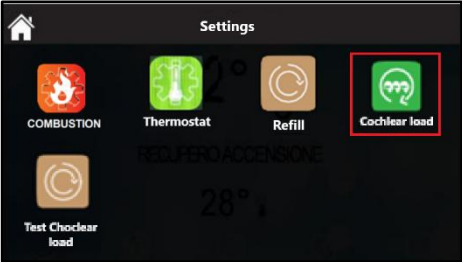

13.1.4. Ignition

At this point the stove will be able to start igniting.

Select the following icon:



Tap the  and swipe to the right

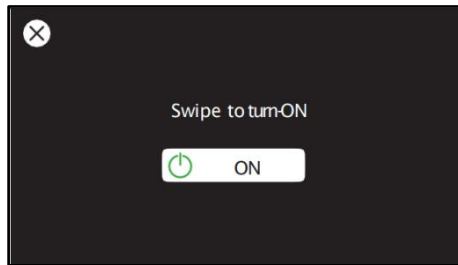

The display should indicate "CHECK-UP", at this point the stove will make a brief check to verify that all components and sensors are functional.

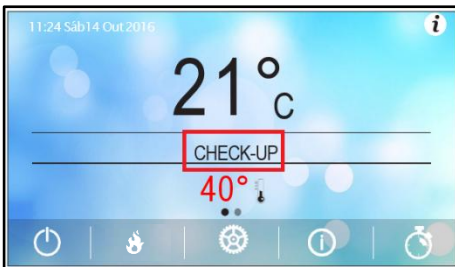

After the stove performs the above check, it will start igniting.

13.1.5. Flame stabilization

The *pellets* will be conducted through the feed channel to the burning basket (combustion chamber), where they will be ignited with the aid of the heating element. This process can take between 5 and 10 minutes, depending on whether the pellet transport auger is pre-loaded or empty with fuel. After the ignition phase is finished, "Stabilization" should appear on the display.



13.1.6. Power level

The heating power can be adjusted at any time. There are two modes of operation of the machine, manual and automatic, so it directly interferes with the ventilation and heat output.

There are five pre-determined power levels/modes (P1, P2, P3, P4 and P5) plus the automatic mode (Auto). Whenever the machine stops, it will take over the last set level/mode.

Click on the following icon:



Select "**Power**"

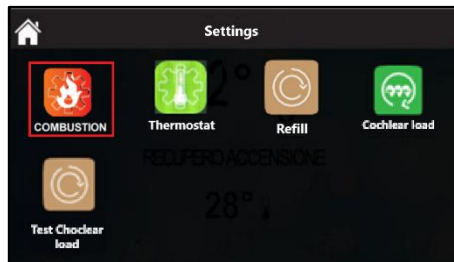

Select "**Combustion**" and choose the

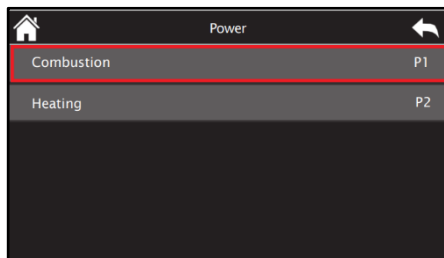

13.1.7. Run mode

The stove is operating normally and according to the settings.



13.1.8. Feeding

Only with the equipment shutting down!

DO NOT PUT fuel directly into the burning basket!

Refill the *pellet tank*

a) Open the lid of the *pellet tank* Figure 11.

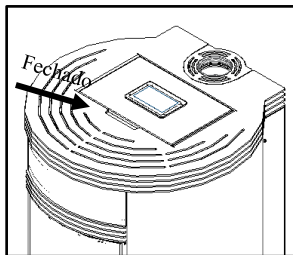

a)

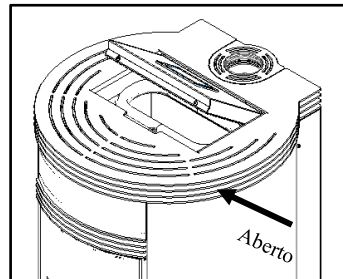

b)

Figure 11 – Opening tank

b) Drop *pellets* into the tank, as shown in Figure 12.



Figure 12 – Refilling the *pellet tank*

c) Close the tank lid and turn on the equipment.

13.1.9. Stop

If the user wishes to abort/stop the operation of the stove, he can do so at any time according to the following instructions:

Click on the following icon:



Tap on  and swipe to the right

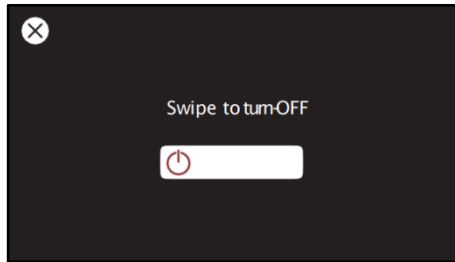

It will appear on the display "STOP"



At this point the stove will no longer power the combustion and will continue to ventilate until the system goes out completely.



14. Maintenance

Stoves require careful maintenance. The main care to be taken is to regularly clean the ashes in the pellet burning area. This can be done in a practical way with the help of a simple ash vacuum cleaner. The cleaning operation should be **EXECUTED** after each burn of approximately, 30kg.

Note: However, before carrying out any cleaning operation, it is imperative that the stove is switched off and cool enough to avoid accidents.

14.1.1. Glass cleaning

Glass can only be cleaned when it is completely cool; It must be cleaned with a suitable product, respecting the instructions for use and preventing the product from reaching the sealing cord and the painted metal parts – so as not to cause unwanted oxidation. The sealing cord is glued and should not be wet with water or cleaning products.



Figure 13 - Incorrect glass cleaning



a)



b)

Figure 14 - Cleaning the glass: a) apply liquid to the cloth; b) Wipe the glass with the cloth

Then clean the inside of the stove by scrubbing the surfaces with accumulated dirt with a brush or cloth, Figure 15.



Figure 15 - Cleaning the interior

Very important: It is also necessary to clean the inside of the stove by simply opening the trapdoor and cleaning inside, as shown in Figure 16.

Finally, assemble the parts in the reverse order in which they were removed and close the door of the appliance.

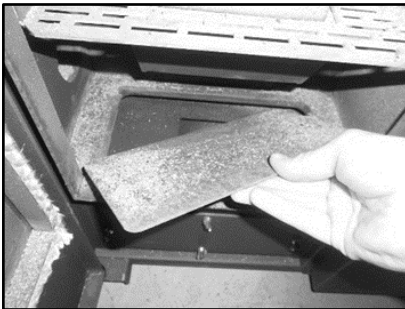

a)



b)

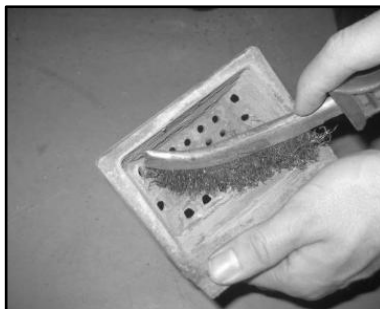

c)

Figure 16 - Cleaning the interior of the stove

 **WARNING!**

ONLY A CORRECTLY POSITIONED AND CLEAN BURNER CAN GUARANTEE THE IGNITION AND CORRECT OPERATION OF THE PELLET STOVE.

14.1.2. Additional cleaning (Periodic)

For every 600-800 kg of *pellets* consumed, in addition to the cleaning process carried out previously, additional maintenance must be carried out.

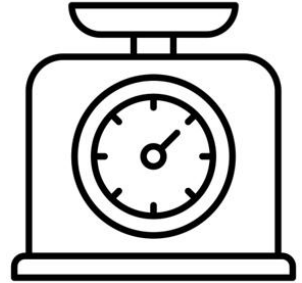

14.1.3. Interior cleaning of combustion chamber

For this equipment its necessary to remove the outside covers to access the inside of combustion chamber. Lets see how to do it:

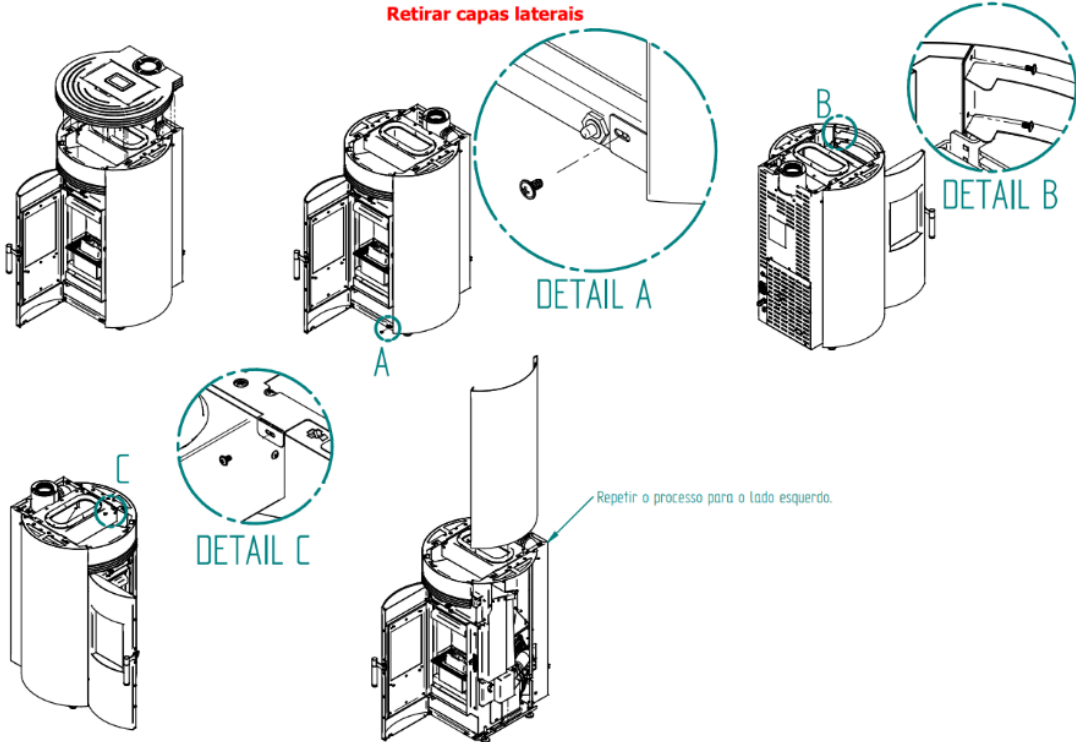

To clean the interior, remove the marked screws (see images below), remove the side covers and remove the ashes with the vacuum cleaner, Figure 18. With the help of a steel brush with a diameter of 20-25 mm and a length of 80 cm. Cleaning the Smoke Zone, Figure 18.

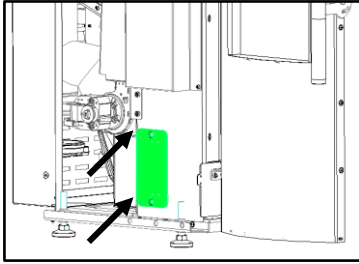
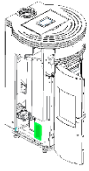

a)

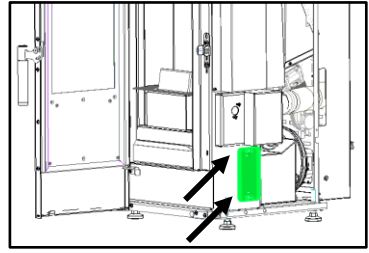

b)

Figure 17 - Caps to be removed from the equipment

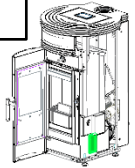

a)



b)

Figure 18 - a) Vacuum the interior; b) Cleaning with a brush

14.1.4. Cleaning Smoke extractor

If it is found that the fume extraction is not being carried out under the best conditions, we recommend cleaning the extractor as shown in Figure 19 and Figure 20. However, this operation is recommended at least once a year. Below is the example of extractor cleaning.



a)



b)

Figure 19 - a) Remove the screws; b) Remove extractor

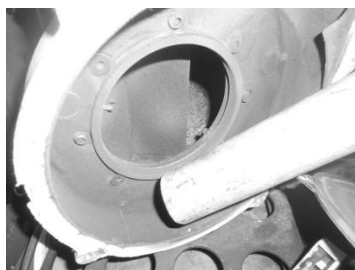

a)



b)

Figure 20 - a) Aspirate the extractor shell; b) Vacuum the pump

14.1.5. Cleaning of the "T" inspection

To clean the inspection "T" installed inside the stove, remove the screws that secure the rear grille. Behind this is the inspection "T", it will be necessary to remove the bottom cover and vacuum the ashes.



Figure 21 - Cleaning the "T" inspection

15. Maintenance plan

To ensure the proper functioning of your stove, it is essential to carry out the maintenance operations that are detailed in chapter 22 of the instruction manual or on the label with the maintenance and cleaning guide. There are tasks that must be done by an authorized technician. Contact the installer. In order not to lose the warranty of your appliance, you must carry out all maintenance with the periodicity indicated in the manual, the technician who does it must complete and sign the maintenance record.

Customer ID:

Name:	
Dress:	
Phone number:	
Model:	
Serial number:	

Company/SAT: _____		
Technical: _____		
Dates: _____		
Service hours of boiler: _____		
Quantity of pellets burned: _____		
Task	Check	Obs.
Clean burner		
Clean smoke circuit and turbulators		
Vacuum pellet tank sawdust		
Check pressure of the expansion vessel		
Check safety valve 3 bar		
Check the fluid on the hydraulic circuit		
Clean the smoke extractor		
Check and clean the inspection T		
Clean chimney		
check the tightening of the screws		
Check engine cap pellet hopper		
_____ Signature/stamp		

Company/SAT: _____		
Technical: _____		
Dates: _____		
Service hours of boiler: _____		
Quantity of pellets burned: _____		
Task	Check	Obs.
Clean burner		
Clean smoke circuit and turbulators		
Vacuum pellet tank sawdust		
Check pressure of the expansion vessel		
Check safety valve 3 bar		
Check the fluid on the hydraulic circuit		
Clean the smoke extractor		
Check and clean the inspection T		
Clean chimney		
check the tightening of the screws		
Check engine cap pellet hopper		
_____ Signature/stamp		

Company/SAT: _____		
Technical: _____		
Dates: _____		
Service hours of boiler: _____		
Quantity of pellets burned: _____		
Task	Check	Obs.
Clean burner		
Clean smoke circuit and turbulators		
Vacuum pellet tank sawdust		
Check pressure of the expansion vessel		
Check safety valve 3 bar		
Check the fluid on the hydraulic circuit		
Clean the smoke extractor		
Check and clean the inspection T		
Clean chimney		
check the tightening of the screws		
Check engine cap pellet hopper		
_____ Signature/stamp		

Company/SAT: _____		
Technical: _____		
Dates: _____		
Service hours of boiler: _____		
Quantity of pellets burned: _____		
Task	Check	Obs.
Clean burner		
Clean smoke circuit and turbulators		
Vacuum pellet tank sawdust		
Check pressure of the expansion vessel		
Check safety valve 3 bar		
Check the fluid on the hydraulic circuit		
Clean the smoke extractor		
Check and clean the inspection T		
Clean chimney		
check the tightening of the screws		
Check engine cap pellet hopper		
_____ Signature/stamp		

Company/SAT: _____
 Technical: _____
 Dates: _____
 Service hours of boiler: _____
 Quantity of pellets burned: _____

Task	Check	Obs.
Clean burner		
Clean smoke circuit and turbulators		
Vacuum pellet tank sawdust		
Check pressure of the expansion vessel		
Check safety valve 3 bar		
Check the fluid on the hydraulic circuit		
Clean the smoke extractor		
Check and clean the inspection T		
Clean chimney		
check the tightening of the screws		
Check engine cap pellet hopper		

Signature/stamp

Company/SAT: _____
 Technical: _____
 Dates: _____
 Service hours of boiler: _____
 Quantity of pellets burned: _____

Task	Check	Obs.
Clean burner		
Clean smoke circuit and turbulators		
Vacuum pellet tank sawdust		
Check pressure of the expansion vessel		
Check safety valve 3 bar		
Check the fluid on the hydraulic circuit		
Clean the smoke extractor		
Check and clean the inspection T		
Clean chimney		
check the tightening of the screws		
Check engine cap pellet hopper		

Signature/stamp

Company/SAT: _____
 Technical: _____
 Dates: _____
 Service hours of boiler: _____
 Quantity of pellets burned: _____

Task	Check	Obs.
Clean burner		
Clean smoke circuit and turbulators		
Vacuum pellet tank sawdust		
Check pressure of the expansion vessel		
Check safety valve 3 bar		
Check the fluid on the hydraulic circuit		
Clean the smoke extractor		
Check and clean the inspection T		
Clean chimney		
check the tightening of the screws		
Check engine cap pellet hopper		

Signature/stamp

Company/SAT: _____
 Technical: _____
 Dates: _____
 Service hours of boiler: _____
 Quantity of pellets burned: _____

Task	Check	Obs.
Clean burner		
Clean smoke circuit and turbulators		
Vacuum pellet tank sawdust		
Check pressure of the expansion vessel		
Check safety valve 3 bar		
Check the fluid on the hydraulic circuit		
Clean the smoke extractor		
Check and clean the inspection T		
Clean chimney		
check the tightening of the screws		
Check engine cap pellet hopper		

Signature/stamp

Company/SAT: _____
 Technical: _____
 Dates: _____
 Service hours of boiler: _____
 Quantity of pellets burned: _____

Task	Check	Obs.
Clean burner		
Clean smoke circuit and turbulators		
Vacuum pellet tank sawdust		
Check pressure of the expansion vessel		
Check safety valve 3 bar		
Check the fluid on the hydraulic circuit		
Clean the smoke extractor		
Check and clean the inspection T		
Clean chimney		
check the tightening of the screws		
Check engine cap pellet hopper		

Signature/stamp

Company/SAT: _____
 Technical: _____
 Dates: _____
 Service hours of boiler: _____
 Quantity of pellets burned: _____

Task	Check	Obs.
Clean burner		
Clean smoke circuit and turbulators		
Vacuum pellet tank sawdust		
Check pressure of the expansion vessel		
Check safety valve 3 bar		
Check the fluid on the hydraulic circuit		
Clean the smoke extractor		
Check and clean the inspection T		
Clean chimney		
check the tightening of the screws		
Check engine cap pellet hopper		

Signature/stamp

Company/SAT: _____
 Technical: _____
 Dates: _____
 Service hours of boiler: _____
 Quantity of pellets burned: _____

Task	Check	Obs.
Clean burner		
Clean smoke circuit and turbulators		
Vacuum pellet tank sawdust		
Check pressure of the expansion vessel		
Check safety valve 3 bar		
Check the fluid on the hydraulic circuit		
Clean the smoke extractor		
Check and clean the inspection T		
Clean chimney		
check the tightening of the screws		
Check engine cap pellet hopper		

Signature/stamp

Company/SAT: _____
 Technical: _____
 Dates: _____
 Service hours of boiler: _____
 Quantity of pellets burned: _____

Task	Check	Obs.
Clean burner		
Clean smoke circuit and turbulators		
Vacuum pellet tank sawdust		
Check pressure of the expansion vessel		
Check safety valve 3 bar		
Check the fluid on the hydraulic circuit		
Clean the smoke extractor		
Check and clean the inspection T		
Clean chimney		
check the tightening of the screws		
Check engine cap pellet hopper		

Signature/stamp

Company/SAT: _____
 Technical: _____
 Dates: _____
 Service hours of boiler: _____
 Quantity of pellets burned: _____

Task	Check	Obs.
Clean burner		
Clean smoke circuit and turbulators		
Vacuum pellet tank sawdust		
Check pressure of the expansion vessel		
Check safety valve 3 bar		
Check the fluid on the hydraulic circuit		
Clean the smoke extractor		
Check and clean the inspection T		
Clean chimney		
check the tightening of the screws		
Check engine cap pellet hopper		
Signature/stamp _____		

Company/SAT: _____
 Technical: _____
 Dates: _____
 Service hours of boiler: _____
 Quantity of pellets burned: _____

Task	Check	Obs.
Clean burner		
Clean smoke circuit and turbulators		
Vacuum pellet tank sawdust		
Check pressure of the expansion vessel		
Check safety valve 3 bar		
Check the fluid on the hydraulic circuit		
Clean the smoke extractor		
Check and clean the inspection T		
Clean chimney		
check the tightening of the screws		
Check engine cap pellet hopper		
Signature/stamp _____		

Company/SAT: _____
 Technical: _____
 Dates: _____
 Service hours of boiler: _____
 Quantity of pellets burned: _____

Task	Check	Obs.
Clean burner		
Clean smoke circuit and turbulators		
Vacuum pellet tank sawdust		
Check pressure of the expansion vessel		
Check safety valve 3 bar		
Check the fluid on the hydraulic circuit		
Clean the smoke extractor		
Check and clean the inspection T		
Clean chimney		
check the tightening of the screws		
Check engine cap pellet hopper		
Signature/stamp _____		

Company/SAT: _____
 Technical: _____
 Dates: _____
 Service hours of boiler: _____
 Quantity of pellets burned: _____

Task	Check	Obs.
Clean burner		
Clean smoke circuit and turbulators		
Vacuum pellet tank sawdust		
Check pressure of the expansion vessel		
Check safety valve 3 bar		
Check the fluid on the hydraulic circuit		
Clean the smoke extractor		
Check and clean the inspection T		
Clean chimney		
check the tightening of the screws		
Check engine cap pellet hopper		
Signature/stamp _____		

Company/SAT: _____
 Technical: _____
 Dates: _____
 Service hours of boiler: _____
 Quantity of pellets burned: _____

Task	Check	Obs.
Clean burner		
Clean smoke circuit and turbulators		
Vacuum pellet tank sawdust		
Check pressure of the expansion vessel		
Check safety valve 3 bar		
Check the fluid on the hydraulic circuit		
Clean the smoke extractor		
Check and clean the inspection T		
Clean chimney		
check the tightening of the screws		
Check engine cap pellet hopper		
Signature/stamp _____		

Company/SAT: _____
 Technical: _____
 Dates: _____
 Service hours of boiler: _____
 Quantity of pellets burned: _____

Task	Check	Obs.
Clean burner		
Clean smoke circuit and turbulators		
Vacuum pellet tank sawdust		
Check pressure of the expansion vessel		
Check safety valve 3 bar		
Check the fluid on the hydraulic circuit		
Clean the smoke extractor		
Check and clean the inspection T		
Clean chimney		
check the tightening of the screws		
Check engine cap pellet hopper		
Signature/stamp _____		

Company/SAT: _____
 Technical: _____
 Dates: _____
 Service hours of boiler: _____
 Quantity of pellets burned: _____

Task	Check	Obs.
Clean burner		
Clean smoke circuit and turbulators		
Vacuum pellet tank sawdust		
Check pressure of the expansion vessel		
Check safety valve 3 bar		
Check the fluid on the hydraulic circuit		
Clean the smoke extractor		
Check and clean the inspection T		
Clean chimney		
check the tightening of the screws		
Check engine cap pellet hopper		
Signature/stamp _____		

Company/SAT: _____
 Technical: _____
 Dates: _____
 Service hours of boiler: _____
 Quantity of pellets burned: _____

Task	Check	Obs.
Clean burner		
Clean smoke circuit and turbulators		
Vacuum pellet tank sawdust		
Check pressure of the expansion vessel		
Check safety valve 3 bar		
Check the fluid on the hydraulic circuit		
Clean the smoke extractor		
Check and clean the inspection T		
Clean chimney		
check the tightening of the screws		
Check engine cap pellet hopper		
Signature/stamp _____		

Company/SAT: _____		
Technical: _____		
Dates: _____		
Service hours of boiler: _____		
Quantity of pellets burned: _____		
Task	Check	Obs.
Clean burner		
Clean smoke circuit and turbulators		
Vacuum pellet tank sawdust		
Check pressure of the expansion vessel		
Check safety valve 3 bar		
Check the fluid on the hydraulic circuit		
Clean the smoke extractor		
Check and clean the inspection T		
Clean chimney		
check the tightening of the screws		
Check engine cap pellet hopper		
_____ Signature/stamp		

Company/SAT: _____		
Technical: _____		
Dates: _____		
Service hours of boiler: _____		
Quantity of pellets burned: _____		
Task	Check	Obs.
Clean burner		
Clean smoke circuit and turbulators		
Vacuum pellet tank sawdust		
Check pressure of the expansion vessel		
Check safety valve 3 bar		
Check the fluid on the hydraulic circuit		
Clean the smoke extractor		
Check and clean the inspection T		
Clean chimney		
check the tightening of the screws		
Check engine cap pellet hopper		
_____ Signature/stamp		

16. Maintenance guide

ATTENTION

WELCOME TO YOUR PELLET STOVE - AIR / HYDRO

This is a quick-start guide. You will find further information in the instruction manual. This guide does not replace the careful reading of the instruction manual.

- 1** **MANUAL**
Read the instruction manual before the first use.
- 2** **PELLETS****
Fill the tank with pellets. For more information see standard EN 14961-2.
- 3** **START (STOP)**
To start or stop, press the On/Off button for **3 seconds**.
- 4** **ADVANCED**
For advanced settings see the advanced section for instruction manual.
- 5** **ALARM**
Any alarm appears on the display and results in **shutdown of the equipment**.
- 6** **LIST OF ALARMS**
You can see the list of alarms and their causes in the instruction manual.
- 7** **ALARM* RESET**
With the flashing alarm signal, press the On/Off button for **10 seconds** and you hear the beep.
- 8** **CLEANING**
Please follow the maintenance and cleaning guide.

MAINTENANCE AND CLEANING GUIDE

Some of the tasks can be done by yourself and others by a technician*.

USER	TECHNICIAN	AIR	HYDRO	DAILY**	WEEKLY**	800 Kg***	ANNUAL
Clean burner		●	●				
Pull turbulators levers and scrape exchanger		●	●				
Clean the hatch compartment		●	●				
Clean ash container		●	●				
Clean smoke circuit and turbulators		●	●				
Vacuum pellet tank sawdust				✓	✓		✓
Check pressure of the expansion vessel						✓	✓
Check the fluid on the hydraulic circuit							✓
Check and clean the expansion T							✓
Clean chimney						✓	✓

* When changing pellets brand it might be necessary to adjust combustion settings. If necessary please call a technician. ** Depends on the quality of pellets. *** In each 500 kg of pellets burned. **** To perform the operation please call your technician. Operation not covered by warranty.

Figure 22 - Maintenance and Cleaning Guide

Note: the warning label is glued by default to the *pellet cap* of the stove in the Portuguese version, next to the stove manual there are labels in several languages (ES, EN, FR and IT) if necessary, remove the label in Portuguese and stick the one in the respective language of the country.

17. Installation and operation of an external “chronothermostat” control system (optional)

Pellet stoves are produced as standard with the control (*display*). Alternatively, the stove can be used with the application of a generic external control (chronothermostat) or another type of control as long as it is a voltage-free contact. To connect the *pellet* equipment remotely through a chronothermostat or thermostat, the interface must be used, Figure 24, it is a plate placed on the right side of the stove Figure 23.

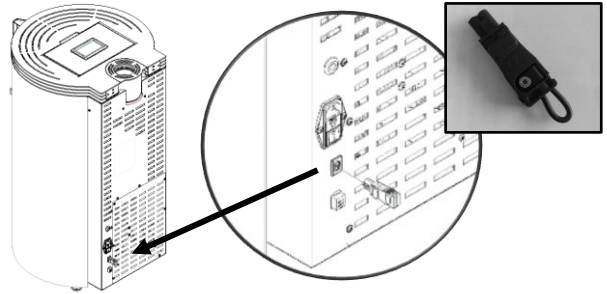

Figure 23 - Location where the interface card is installed

Note: the external command, as a rule, is accompanied by a manual. To use the external control, you need to connect the cables of the external chronothermostat to the plug (Figure 24).

Note: the contact of the chronothermostat must be without voltage 230V (dry contact). If the thermostat input is connected, the power of the machine will only vary between minimum power (NO open contact) and maximum power (NC closed contact).



Figure 24 - External control (programmable thermostat)

18. Electrical schematic of the stove

18.1. Electrical schematic

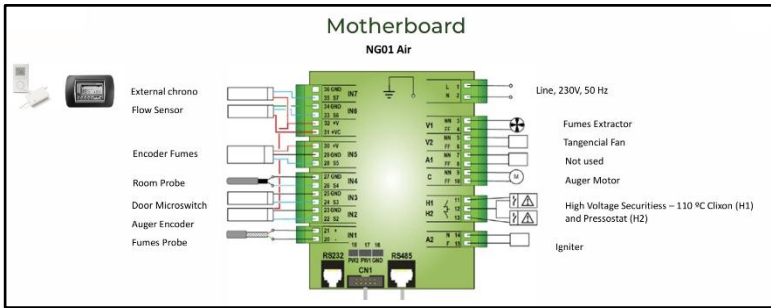

Figure 25 - Electrical schematic

19. Recycling

About 90% of the materials used in the manufacture of the equipment are recyclable, thus contributing to lower environmental impacts and contributing to the sustainable development of the Planet. Therefore, end-of-life equipment must be sent to licensed waste operators, so it is advisable to contact your municipality so that it can be correctly collected.

20. Warranty

1. Corporate name and address of the Producer

This document does not constitute the provision by Fogo Montanha of a voluntary guarantee on the products produced and marketed by it (hereinafter "Product(s)"), but rather a guide, which is intended to be clarifying, for the effective activation of the legal guarantee that consumers benefit from on the Products (hereinafter "Warranty"). Of course, this document does not affect the Buyer's statutory warranty rights arising from a contract of sale with respect to the Products.

2. Identification of the Product on which the Warranty falls

The activation of the Warranty presupposes the prior and correct identification of the Product subject to it with Fogo Montanha, to be promoted by indicating the data on the Product's packaging contained both in the respective purchase invoice and in the Product's rating plate (model and serial number).

3. Product Warranty Conditions

3.1 Fogo Montanha shall be liable to the Buyer for the lack of conformity of the Product with the respective purchase and sale contract within the following time limits:

3.1.1 A period of 24 months from the date of delivery of the goods, in the case of domestic use of the product;

3.1.2 A period of 6 months from the date of delivery of the goods, in the case of professional, industrial, or intensive use of the products – Fogo Montanha understands professional, industrial, or intensive use as all products installed in industrial or commercial spaces, or whose use exceeds 1500 hours per calendar year;

3.2 A functional test of the product must be carried out before carrying out the finishing of the installation (plasterboard, masonry, coatings, paintings, among others);

3.3 No equipment can be replaced after the 1st Burning without express authorization from the producer;

3.4 Any and all products must be repaired at the installation site without causing serious inconvenience to the parties, except if this proves impossible, or disproportionate;

3.5 In order to exercise its rights, and provided that the period indicated in 3.1 is not exceeded, the Buyer must report in writing to Fogo Montanha the lack of conformity of the Product within a maximum period of:

3.5.1 60 (sixty) days from the date on which it was detected, in the case of domestic use of the product;

3.5.2 30 (thirty) days from the date on which you have detected it, in the case of professional use of the Product.

3.6 In the equipment of the pellet family, the start-up service is required to activate the warranty. This must be recorded up to 3 months before the invoice date, or 100 hours of product work (whichever occurs first);

3.7 During the Warranty period referred to in paragraph 3.1 above (and in order for it to remain valid), repairs to the Product must be carried out exclusively by the Official Technical Services of the Brand. All services provided under this Guarantee will be carried out from Monday to Friday within the working hours and calendar legally established in each region.

3.8 All requests for assistance must be submitted to Fogo Montanha' customer service, available on the www.FogoMontanha.com website. At the time of technical assistance to the Product, the Purchaser must present, as proof of the Product Warranty, the purchase invoice for the same or another document demonstrating its purchase. In any case, the document proving the purchase of the Product must contain the identification of the same (under the terms referred to in 2 above) and its date of purchase. Alternatively and in order to validate the Product Warranty, the PSR - document proving the start of the machine (when applicable) may be used.

3.9 The Product must be installed by a qualified professional for this purpose, in accordance with the regulations in force in each geographical area, for the installation of these Products and complying with all regulations in force, namely those regarding chimneys, as well as other applicable regulations for aspects such as water supply, electricity and/or others related to the equipment or sector and as described in the instruction manual.

An installation of a Product that does not comply with the manufacturer's specifications and/or that does not comply with the legal regulations on this matter, will not give rise to the application of this Warranty. Whenever a Product is installed outdoors, it must be protected against weather effects, such as rain and wind. In these cases, it may be necessary to protect the device by means of a cabinet or a properly ventilated protective box.

Appliances should not be installed in places that contain chemicals in their atmosphere, saline environments or with high humidity contents, as mixing them with air can produce rapid corrosion in the combustion chamber. Neste tipo de ambientes

It is especially recommended that the appliance be protected with anti-corrosion products for this purpose, especially between periods of operation. As a suggestion, the application of graphite greases indicated for high temperatures with lubrication function and anti-corrosion protection is indicated.

3.10 In equipment belonging to the pellet family, in addition to the daily and weekly maintenance contained in the instruction manual, it is also mandatory to clean the interior and its smoke evacuation chimney. These tasks should be carried out for every 600-800 kg of pellets consumed, in the case of stoves (air and water) and compact boilers, and for every 2000-3000 kg of pellets consumed, for automatic boilers. In the event that these quantities are not consumed, at least systematic preventive maintenance must be carried out annually.

3.11 It is the responsibility of the Purchaser to ensure that periodic maintenance is carried out, as indicated in the instruction and handling manuals that accompany the Product. Whenever requested, it must be proven by the presentation of the technical report of the entity responsible for it, or, alternatively, by registering them in the instruction manual in the dedicated section.

3.12 To avoid damage to equipment caused by overpressure, safety elements such as pressure safety valves and/or thermal discharge valves, if applicable, as well as an expansion vessel adjusted to the installation, must be ensured, and its correct operation must also be ensured. It should be noted that: the referenced valves must have a value equal to or less than the pressure supported by the equipment; there must be no shut-off valve between the equipment and its safety valve; a systematic preventive maintenance plan should be provided to attest to the correct functioning of these security features; Regardless of the type of appliance, all safety valves must be piped to siphon sewage, to prevent damage to the house by water discharges. The Product Warranty does not include damage caused by the failure to channel the water discharged by said valve.

3.13 To avoid damage to equipment and attached piping due to galvanic corrosion, it is advisable to use dielectric separators (cuffs) in the connection of the equipment to metal pipes whose characteristics of the applied materials potentiate this type of corrosion. The Product Warranty does not include damage caused by the non-use of said dielectric separators.

3.14 The water or thermofluidic used in the heating system (Hydro stoves, boilers, stoves, central heating, among others) must comply with the current legal requirements, as well as guarantee the following physicochemical characteristics: absence of suspended solid particles; low level of conductivity; residual hardness of 5 to 7 French degrees; Neutral pH, close to 7; low concentration of chlorides and iron; and absence of air intakes due to depression or others. If the installation provides an automatic water make-up, it must consider upstream a preventive treatment system consisting of filtration, descaling and preventive dosing of polyphosphates (scale and corrosion), as well as a degassing stage, if necessary. If under any circumstances any of these indicators presents values outside the recommended range, the Guarantee will cease to be effective. It is also mandatory to place a non-return valve between the automatic filling valve and the mains water supply, as well as that the supply always has constant pressure, even in the absence of electricity, not depending on pumps, autoclaves, or other.

3.15 Except as expressly provided for by law, a warranty intervention does not renew the warranty period of the Product. Warranty rights are not transferable to the purchaser of the Product.

3.16 The equipment must be installed in accessible places and without risk to the technician. The necessary means for access to them will be made available by the Buyer, who will be responsible for any charges arising therefrom.

3.17 The Warranty is valid for Products and equipment sold by Fogo Montanha only and exclusively within the geographical and territorial area of the country where the Product was sold by Fogo Montanha.

4. Circumstances that exclude the application of the Warranty

The following cases are excluded from the Warranty, with the total cost of the repair being borne by the Buyer:

4.1. Products with more than 2000 operating hours;

4.2. Refurbished and resold products.

4.3. Maintenance operations, Product adjustments, start-ups, cleaning, elimination of errors or anomalies that are not related to deficiencies in equipment components and replacement of batteries;

4.4. Components in direct contact with fire such as: vermiculite supports, deflector or protection plates, vermiculite, sealing cords, burners, ash drawers, wood chippers, smoke registers, ash grids, whose wear is directly related to the conditions of use.

Degradation of the paint, as well as the appearance of corrosion due to its degradation, due to excess fuel load, use of an open drawer or excessive drawing of the installation chimney (the chimney must comply with the recommended draft in the Product's Technical Data Sheet-SFT). The breakage of the glass due to improper handling or other reason unrelated to the

deficiency of the Product. In the pellet family equipment, the ignition resistors are a wearing part, so they only have a 6-month warranty, or 1000 ignitions (whichever occurs first);

4.5. Components considered to be wearing, such as bearings, bushings and bearings;

4.6. Deficiencies of components external to the Product that may affect its correct functioning, as well as material or other damage (e.g. tiles, roofs, waterproofed roofs, pipes, or personal injury) caused by the improper use of materials in the installation or by the failure to carry out the installation in accordance with the installation standards of the Product, applicable regulations or rules of good art, namely when the application of piping appropriate to the temperature in use, expansion vessels, non-return valves, safety valves, anti-condensation valves, among others, has not been promoted;

4.7. Products whose operation has been affected by failures or deficiencies of external components or by poor dimensioning;

4.8. Defects caused by the use of accessories or replacement Components other than those determined by Fogo Montanha;

4.9. Defects resulting from non-compliance with the instructions for installation, use and operation or from applications that do not conform to the use for which the Product is intended, or from abnormal climatic factors, strange operating conditions, overload or improperly performed maintenance or cleaning;

4.10. Products that have been modified or manipulated by persons outside the Official Technical Services of the brand and consequently without explicit authorisation from Fogo Montanha;

4.11. Damage caused by external agents (rodents, birds, spiders, etc.), atmospheric and/or geological phenomena (earthquakes, storms, frost, hail, thunderstorms, rain, etc.), aggressive humid or saline environments (e.g. proximity to the sea or river), as well as those caused by excessive water pressure, inadequate power supply (voltage with variations greater than 10%, compared to the nominal value of 230V, or, voltage in neutral greater than 5V, or, absence of earth protection), pressure or supply of inadequate circuits, acts of vandalism, urban clashes and armed conflicts of any kind, as well as derivatives;

4.12. Failure to use fuel recommended by the manufacturer is a condition of exclusion from the Warranty;

Explanatory note: In the case of pellet appliances, the fuel used must be certified to EN 14961-2 grade A1. Likewise, before buying large quantities you should test the fuel to check how it behaves.

In firewood equipment, this must have a moisture content of less than 20 %.

4.13. The appearance of condensation, either by poor installation or by the use of fuels other than virgin wood (such as pallets or wood impregnated with paints or varnishes, salt or other components), which may contribute to the accelerated degradation of the equipment, especially its combustion chamber;

4.14. All Products, Components or components damaged in shipping or installation;

4.15. Cleaning operations carried out on the appliance or its components, caused by condensation, fuel quality, poor adjustment or other circumstances of the place where it is installed. Likewise, interventions for the descaling of the Product (the elimination of limescale or other materials deposited inside the appliance and produced by the quality of the water supply) are excluded from the Warranty. Likewise, interventions such as air draining from the circuit or unblocking circulator pumps are excluded from this Warranty.

4.16. The installation of the equipment supplied by Fogo Montanha must include the possibility of easy removal of the same, as well as access points to the mechanical, hydraulic and electronic components of the equipment and the installation. When the installation does not allow immediate and secure access to the equipment, the additional costs of means of access and security will always be borne by the Buyer. The cost of dismantling and assembling plasterboard bins or masonry walls, insulation or other elements such as chimneys and hydraulic connections that prevent free access to the Product (if the Product is installed inside a plasterboard, masonry or other dedicated space, it must comply with the dimensions and characteristics indicated in the instruction and use manual that comes with the appliance).

4.17. Information or clarification interventions at home on the use of its heating system, programming and/or reprogramming of regulation and control elements, such as thermostats, regulators, programmers, etc.;

4.18. Fuel adjustment interventions in pellet appliances, cleaning, detection of water leaks in the pipes external to the appliance, damage caused due to the need to clean the machines or gas evacuation chimneys;

4.19. Emergency interventions not included in the provision of the Guarantee, i.e., interventions on weekends and holidays, as they are special interventions not included in the coverage of the Guarantee and which therefore have an additional cost, will be carried out exclusively at the express request of the Buyer and subject to the availability of the Producer.

5. **Inclusion of the Warranty**

Fogo Montanha will correct, at no cost to the Purchaser, the defects covered by the Warranty, by repairing the Product. The replaced Products or Components will become the property of Fogo Montanha.

6. **Fogo Montanha Liability**

Without prejudice to the legal provisions, Fogo Montanha' liability in terms of warranty is limited to what is established in these Warranty Conditions.

7. **Tariff Services performed outside the scope of Warranty**

As intervenções realizadas fora do âmbito da Garantia estão sujeitas à aplicação do tarifário em vigor.

8. **Warranty Services performed outside the scope Warranty**

Interventions carried out outside the scope of the Warranty carried out by the official Fogo Montanha technical assistance service have a 6-month warranty.

9. **Warranty Spare Parts supplied by Fogo Montanha**

As Peças fornecidas pela Fogo Montanha, no âmbito da venda comercial de spare parts, isto é, não incorporados nos equipamentos não dispõem de garantia.

10. **Replaced Parts Scope Technical Assistance Service**

Used Parts from the moment they are removed from the equipment as a whole acquire waste status. Fogo Montanha, as a producer of waste within the scope of its activity, is obliged by the legislation in force to deliver it to a licensed entity that carries out the necessary waste management operations under the terms of the law and therefore prevented from giving it any other destination, whatever it may be. Therefore, the customer will be able to view the used parts resulting from the service, but will not be able to keep them in his possession.

11. **Administrative Expenses**

In the case of invoices referring to services performed whose payment is not made within the stipulated period, default interest will be added at the maximum legal rate in force.

12. **Competent Court**

For the resolution of any dispute arising from the purchase and sale contract with the object of the Products covered by the Warranty, the Contracting Parties attribute exclusive jurisdiction to the jurisdiction of the district of Águeda, with express waiver of any other.

21. Flow chart

21.1. Flow chart 1 – activation

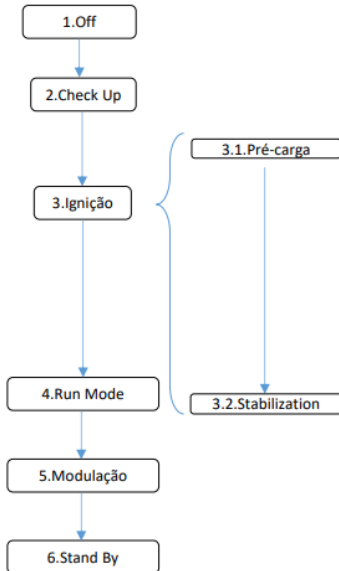

The **pre-charge** phase aims to supply the burning cup with *pellets* to a sufficient level so that ignition can occur more easily.

22. Declaration of performance.

DECLARAÇÃO DE DESEMPENHO | DECLARACIÓN PRESTACIONES | DECLARATION OF PERFORMANCE | DÉCLARATION DE PERFORMANCE |
DICHIARAZIONE DELLE PRESTAZIONI

N.º DD-065

1. Código de identificação único do produto-tipo | Código de identificación único del tipo de producto | Unique identification code of the product type | Le code d'identification unique du type de produit | Codice unico di identificazione del tipo di prodotto

EDGE BLACK – EAN05600990555167

EDGE WHITE – EAN05600990555112

2. Número do tipo, lote ou série do produto | Número de tipo, lote o serie del producto | Number of type, batch or serial product | Nombre de type, de lot ou de série du produit | Numero di tipo, di lotto, di serie del prodotto

3. Utilização prevista | Uso previsto | Intended use | Utilisation prévue | Destinazione d'uso

*AQUECIMENTO DE EDIFÍCIOS DE HABITAÇÃO | CALEFACCIÓN DE EDIFICIOS RESIDENCIALES | HEATING OF RESIDENTIAL BUILDINGS |
CHAUFFAGE DE BATIMENTS RESIDENTIELS | RISCALDAMENTO DEGLI EDIFICI RESIDENZIALI*

4. Nome, designação comercial registada e endereço de contacto do fabricante | Nombre, marca registrada y la dirección de contacto de lo fabricante | Name, registered trade name and contact address of the manufacturer | Nom, marque déposée et l'adresse de contact du fabricant | Nome, denominazione commerciale registrata e Indirizzo del costruttore

SOLZAIMA SA

RUA DA COVA DA AREIA (E.M. 605), 695

3750-071 AGUADA DE CIMA – ÁGUEDA – PORTUGAL

5. Sistema de avaliação e verificação da regularidade do desempenho do produto | Sistema de evaluación y verificación de constancia de las prestaciones del producto | System of assessment and verification of constancy of the product | Système d'évaluation et de vérification de la Constance des performances du produit | Sistema di valutazione e verifica della costanza della prestazione del prodotto

SISTEMA 3

6. Norma Harmonizada | Estandár armonizado | Harmonized standard | Norme harmonisée | Standard armonizzata

EN 14785

7. Nome e número de identificação do organismo notificado | Nombre y número de identificación del organismo notificado | Name and identification number of the notified body | Nom et numéro d'identification de l'organisme notifié | Nome e numero di identificazione dell'organismo notificato

CEIS – CENTRO DE ENSAYOS INOVACION Y SERVICIOS

NB: 1722

8. Relatório de ensaio | Informe de la prueba | Test report | Rapport d'essai | Rapporto di prova

CEE-0008/18-5

CEE-0009/18-5

9. Desempenho declarado | Desempeño declarado | Declared performance | Performance déclarée | Dichiarazione di prestazione

Característicos essenciais Características esenciales Essencial characteristics Caratteristiche essenziali Caractéristiques essentielles Caratteristiche essenziali	Desempenho Desempeño Performance Prestazione	Especificações técnicas harmonizadas Especificaciones técnicas armonizadas Harmonized technical specifications Spécifications techniques harmonisées Specifiche tecniche armonizzate
Segurança contra incêndio Seguridad contra incendios Fire safety Sécurité incendie Sicurezza antincendio	OK. De acordo com relatório de ensaio De acuerdo con informe de la prueba According to the test report Selons le rapport d'essai Secondo i rapporti di prova CEE-0008/18-5 CEE-0009/18-5	De acordo com os requisitos De acuerdo con los requisitos According to the requirements Selons les exigences Secondo i requisiti 4.2, 4.3, 4.7, 4.8, 4.10, 4.11, 5.1, 5.3, 5.4, 5.5, 5.8 (EN14785)
Emissão de produtos da combustão La emisión de productos de combustión Emission of combustion products Emission des produits de combustion Emissione dei prodotti di combustione	OK. Caudal térmico nominal Caudal térmico nominale Nominal heat output Le débit calorifique nominal Nominal heat output Flusso termico nominale –CO:0,01%	Caudal térmico nominal Caudal térmico nominale Nominal heat output Le débit calorifique nominal Nominal heat output Flusso termico nominale –CO<0,04%
Libertação de substâncias perigosas Emisión de sustancias peligrosas Release of dangerous substances Dégagement de substances Rilascio di sostanze pericolose	OK. De acordo com relatório de ensaio De acuerdo con informe de la prueba According to the test report Selons le rapport d'essai Secondo i rapporti di prova CEE-0008/18-5 CEE-0009/18-5	De acordo com o Anexo ZA.1 (EN14785) De acuerdo con lo Anexo ZA.1 (EN14785) According to the Annex ZA.1 (EN14785) Selons l'Annexe ZA.1 (EN14785) Secondo l'allegato ZA.1 (EN14785)
Temperatura de superfície Temperatura de la superficie Surface temperature La température de surface Temperatura superficiale	OK. De acordo com relatório de ensaio De acuerdo con informe de la prueba According to the test report Selons le rapport d'essai Secondo i rapporti di prova CEE-0008/18-5 CEE-0009/18-5	De acordo com os requisitos De acuerdo con los requisitos According to the requirements Selons les exigences Secondo i requisiti 4.2, 4.13, 5.1, 5.2, 5.4, 5.5 (EN14785)
Segurança elétrica Seguridad eléctrica Electrical safety Sécurité électrique sicurezza elettrica	OK. De acordo com relatório de ensaio De acuerdo con informe de la prueba According to the test report Selons le rapport d'essai Secondo i rapporti di prova CEE-0008/18-5 CEE-0009/18-5	De acordo com os requisitos De acuerdo con los requisitos According to the requirements Selons les exigences Secondo i requisiti 5.9 (EN14785)
Aptidão para ser limpo Capacidad para ser limpiado Ability to be cleaned Possibilité d'être nettoyé Capacità di essere puliti	OK. De acordo com relatório de ensaio De acuerdo con informe de la prueba According to the test report Selons le rapport d'essai Secondo i rapporti di prova CEE-0008/18-5 CEE-0009/18-5	De acordo com os requisitos De acuerdo con los requisitos According to the requirements Selons les exigences Secondo i requisiti 4.5, 4.6, 4.10, 4.12 (EN14785)
Temperatura dos gases de combustão Temperatura de los gases de combustión Temperature of the flue gas Température du gaz de fumée Temperatura dato fumi	OK. 137°C	De acordo com os requisitos De acuerdo con los requisitos According to the requirements Selons les exigences Secondo i requisiti 6.2 (EN14785)
Resistência mecânica Resistencia mecánica Mechanical strength résistance Resistenza meccanica	OK. De acordo com relatório de ensaio De acuerdo con informe de la prueba According to the test report Selons le rapport d'essai Secondo i rapporti di prova CEE-0008/18-5 CEE-0009/18-5 A cada 10 m de conduta de fumos deve ser colocado um suporte de carga cada 10 m de la salida de humos se debe colocar un soporte de carga every 10 m of the flue should be placed a load support tous les 10 m de conduit de fumée doit être placé un support de charge ogni 10 m della canna fumaria deve essere posto un supporto di carico	De acordo com os requisitos De acuerdo con los requisitos According to the requirements Selons les exigences Secondo i requisiti 4.2, 4.3(EN14785)

Potência térmica Potencia térmica Thermic output Puissance thermique Potenza termico	OK. 7 kW	De acordo com os requisitos De acuerdo con los requisitos According to the requirements Selons les exigences Secondo i requisiti 6.1, 6.4 – 6.10 (EN14785)
Rendimento energético Eficiencia energética Energy efficiency L'efficacité énergétique Efficienza energetica	OK. 92%	≥ 75% para potência térmica nominal de potencia térmica nominal for rated thermal input Pour puissance thermique nominale di potenza termica nominale
	OK. 96%	≥ 70% para potência térmica reduzida la reducción térmica to reduced thermal à la réduction thermique di potenza termica ridotto
Durabilidade Durabilidad Durability Durabilité Durabilità	OK. De acordo com relatório de ensaio De acuerdo com informe de la prueba According to the test report Selons le rapport d'essai Secondo i rapporti di prova CEE-0008/18-5 CEE-0009/18-5	De acordo com os requisitos De acuerdo con los requisitos According to the requirements Selons les exigences Secondo i requisiti 4.2 (EN14785)

10. Distância mínima a materiais combustíveis (laterais/frente/topo/posterior) | Distancia mínima a materiales combustibles (laterales/frente/topo/trasero) | Minimum distance to combustible materials (side/front/top/back) | Distance minimale aux matériaux combustibles (côte/avanta/haut/arrière) | Distanza minima da materiali combustibili (lato/anteriore/top/posteriore)

(500 mm / 1500 mm / 1000 mm / 500 mm)

11. O desempenho do produto declarado nos pontos 1 e 2 é conforme com o desempenho declarado no ponto 9. A presente declaração de desempenho é emitida sob exclusiva responsabilidade do fabricante identificado no ponto 4. | El funcionamiento del producto se indica en los puntos 1 y 2 es compatible con las prestaciones declaradas en el punto 9. La presente declaración se expide bajo la exclusiva responsabilidad del fabricante identificado en lo punto 4. | Performance of the product stated in points 1 and 2 is consistent with the declared performance in point 9. This declaration of performance is issued under the sole responsibility of the manufacturer identified in point 4. | Les performances du produit indiqué dans les points 1 et 2 est compatible avec les performances declares au point 9. Cette déclaration de performance est établie sous la seule responsabilité du fabricant identifié dans le point 4. | Le prestazioni dei prodotti indicati ai punti 1 e 2 è conforme alla prestazione dichiarata al punto 9. Questa dichiarazione di prestazione è rilasciata sotto l'esclusiva responsabilità del fabbricante di cui al punto 4

Nome e cargo | Nombre y cargo | Name and title | Nom et titre | Nome e titolo
06/10/2025
Nuno Sequeira (Director Geral | CEO)

Aguada de Cima,